



# Parts and Specific Operations Manual



## ***ECT20000 TWIN REEL, SINGLE TURRET***

MGS Incorporated , 178 Muddy Creek Church Road, Denver, PA 17517  
PH 1-800-952-4228

# Table of Contents



3 ..... Introduction/Pertinent Information

4-10 ..... Specific Operation

11 ..... Body Component Identification

12 ..... Hub Component Identification

13 ..... Brake Component Identification

14 ..... Suspension Component Identification

15-19 ..... Maintenance Information

20-21 ..... Warranty information

22 ..... NHSTA Statement



MGS Inc. was established in 1962 by owner and president Roland Gehman. The company's corporate culture is a direct reflection of Roland's desires, capabilities, and attitudes. These attitudes have developed from his experiences and relationships with his family, education, church, volunteer groups, business associates and MGS employees. We are staffed with an extraordinary group of talented people. The members of MGS consist of : salesmen, welders, sales support personnel, press and shear operators, engineers, tow motor operators, shipping and receiving personnel, purchasing agents, production controllers, administrative personnel, supervisors, painters, mechanics, cad operators, maintenance men, truck drivers, carpenters, and managers. All of which, have an impact on who we are:

## INNOVATORS AND MANUFACTURERS OF TRANSPORTATION EQUIPMENT

### The MGS Mission :

It is our mission to provide *the best total solution* for our customers, clients and alliance partners. These solutions are built like our products, with TEAMWORK. The combined expertise and efforts of the MGS team is what keeps us **one of a kind - not one of a group!**

## About Your Trailer

MGS Model No.	ECT20000
Description	Twin Reel, Single Turret Trailer
GAWR	6,000#
GVWR	6,600#
Empty Weight	2,840#
Unladen Hitch Weight	380#
Tire Size	235/80R16
Coupler	Eye 3" - 2 bolt Adjustable
Electrical Connection	7 way plug

This hazard alert sign appears in this manual. When you see this sign, carefully read what it says.  
**YOUR SAFETY IS AT STAKE.**



Indicates an imminently hazardous situation which, if not avoided, will result in death or serious injury.



Indicates an potentially hazardous situation which, if not avoided, could result in death or serious injury.



Indicates a hazardous situation which if not avoided, may result in minor or moderate injury

## Read and Understand

Do not operate this equipment until you have carefully read, and understand the “Safety” and “Operation” sections of this manual, and of all other equipment manuals that will be used with it. Your safety and the safety of others depends upon care and judgement in the operation of this equipment. Follow all applicable federal, state, local, and industry specific regulations. MGS Inc. cannot anticipate every possible circumstance that might involve a potential hazard. The warnings in this manual and on the machine are therefore not all inclusive. You must satisfy yourself that a procedure, tool, work method, or operating technique is safe for you and others. You should also ensure that the machine will not be damaged or made unsafe by the method of operation or maintenance you choose.

## ROTATING THE TURRET



Turret locking mechanism is located under the expanded metal deck panel on the road side of the trailer



1

1. Turret Lock shown in engaged position Turrets should be locked in this position during transport and pulling operations



WARNING

Never attempt to transport or pay out cable if turret lock is not in position#1



2-3

2. Pull back on safety latch and rotate until roll pin engages in released position as shown

3. Rotate release handle clockwise to clear the handle guard.



4

4. Pull handle toward you until it stops to release the turret lock.

Turret locks in 45 degree increments to allow eight different positions

## ROTATING THE TURRET

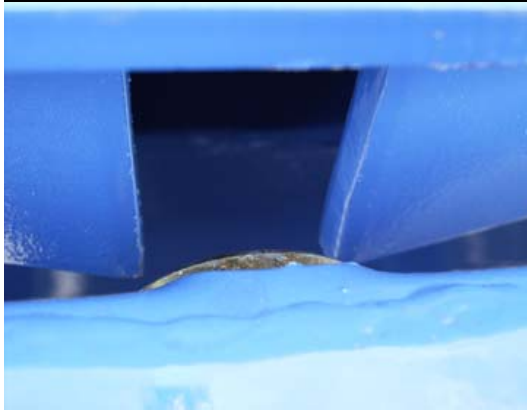

In this photo, the lock pin is fully retracted to allow the turret to rotate



It is possible to check for proper alignment through the top of the deck near the turret assy. Here is a photo of the locking pin fully extended into one of the locking slots in the turret.



 **WARNING**

The turret is a crush hazard. Make sure all body parts are clear of the travel area prior to movement of the turret



 **WARNING**

Never attempt to transport or pay out cable if turret lock is not in this position with the safety engaged

## LOWERING THE SELF - STORE STEP

---



There are two retractable steps to gain access to the deck of the trailer. They are located near the front of the deck on the curb side and road side near the front amber clearance light



To lower the step, pull out on the spring latch and rotate in order to engage the roll pin as shown



Pull the step out fully prior to use.

Reverse this procedure to stow making sure to engage the latch by pulling and rotating in the opposite direction. Never tow the trailer with the steps deployed.

## ***REMOVING THE REEL BARS***

---

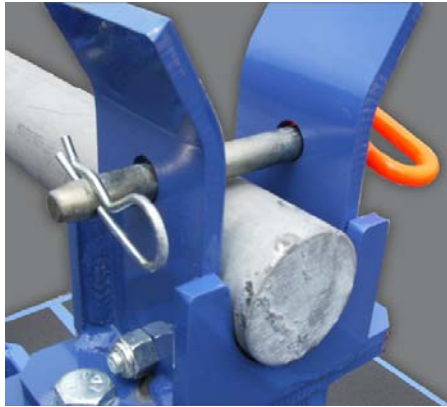

To remove reel bars, pull pins on both sides of bar

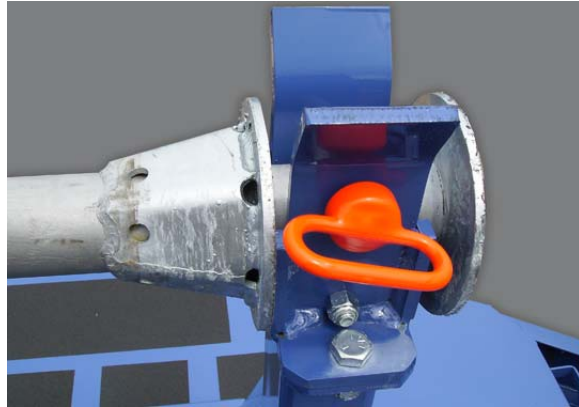

Make sure that the pins are replaced prior to transport

## ***TONGUE MOUNTED TOOL BOX***

---

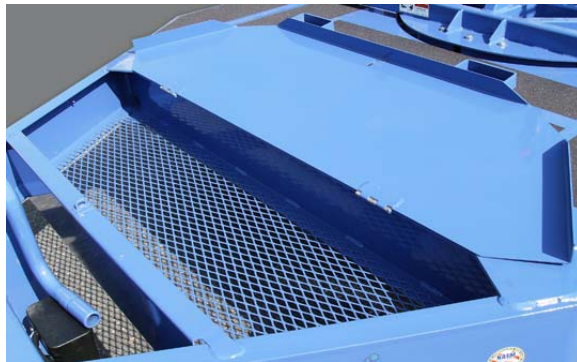

Tool box lid should not be in this position when turret is rotated. Damage to the turret or lid will result

# Electric Brakes

## *Operation*

The electric brakes on your trailer are similar to the drum brakes on your automobile. The basic difference is that your automotive brakes are actuated by hydraulic pressure while your electric trailer brakes are actuated by an electromagnet. With all of the brake components connected into the system, the brake should operate as follows:

When the electrical current is fed into the system by the controller, it flows through the electromagnets in the brakes. The high capacity electromagnets are energized and are attracted to the rotating armature surface of the drums which moves the actuating levers in the direction that the drums are turning.

The resulting force causes the actuating cam block at the shoe end of the lever to push the primary shoe out against the inside surface of the brake drum. The force generated by the primary shoe acting through the adjuster link then moves the secondary shoe out into contact with the brake drum.

Increasing the current flow to the electromagnet causes the magnet to grip the armature surface of the brake drum more firmly. This results in increasing the pressure against the shoes and brake drums until the desired stop is accomplished.

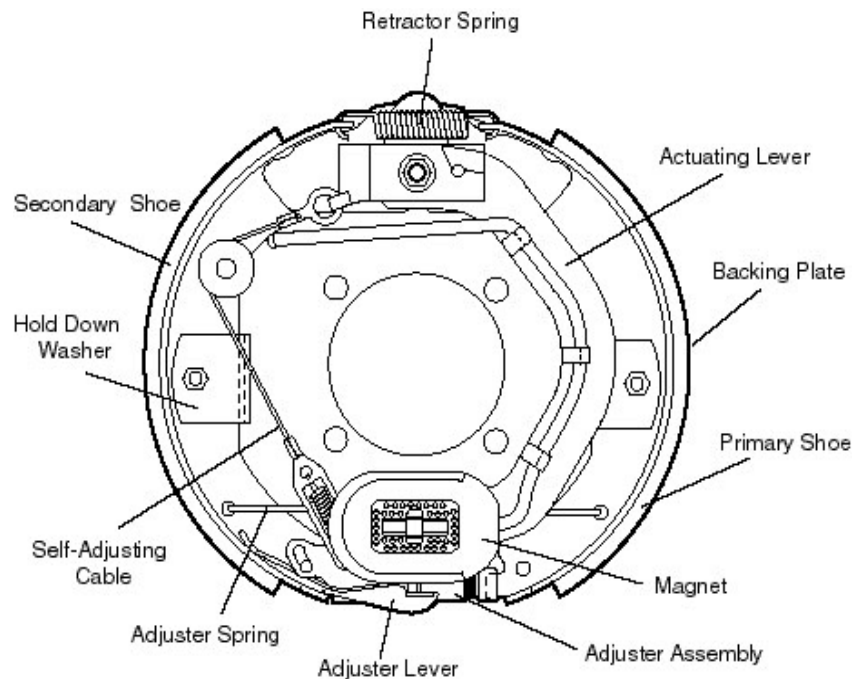

### **Controllers**

Start by making sure the trailer brakes are properly adjusted. Some controllers have a gain control to vary the amount of current to the brakes, and a level control which sets the controller's inertia sensor to sense deceleration. The level adjustment also can be used to vary when the trailer braking is felt. The gain or output control adjustment usually controls the maximum amount of amperage available to the brakes. This control can be adjusted for varying trailer loads.

## How To Use Your Electric Brakes Properly

Your trailer brakes are designed to work in synchronization with your tow vehicle brakes. Never use your tow vehicle or trailer brakes alone to stop the combined load.

Your trailer and tow vehicle will seldom have the correct amperage flow to the brake magnets to give you comfortable, safe braking unless you make proper brake system adjustments. Changing trailer load and driving conditions as well as uneven alternator and battery output can mean unstable current flow to your brake magnets. It is therefore imperative that you maintain and adjust your brakes as set forth in this manual, use a properly modulated brake controller, and perform the synchronization procedure.

In addition to the synchronization adjustment detailed below, electric brake controllers provide a modulation function that varies the current to the electric brakes with the pressure on the brake pedal or amount of deceleration of the tow vehicle. It is important that your brake controller provide approximately 2 volts to the braking system when the brake pedal is first depressed and gradually increases the voltage to 12 volts as brake pedal pressure is increased. If the controller “jumps” immediately to a high voltage output, even during a gradual stop, then the electric brakes will always be fully energized and will result in harsh brakes and potential wheel lockup.

Proper synchronization of tow vehicle to trailer braking can only be accomplished by road testing. Brake lockup, grabbiness, or harshness is quite often due to the lack of synchronization between the tow vehicle and the trailer being towed, too high of a threshold voltage (over 2 volts), or under adjusted brakes.

Before any synchronization adjustments are made, your trailer brakes should be burnished-in by making 20-30 full stops from approximately 20 m.p.h. This allows the brake shoes and magnets to slightly “wear-in” to the drum surfaces.

### To Synchronize

To insure safe brake performance and synchronization, read the brake controller manufacturer’s instructions completely before attempting any synchronization procedure.

#### CAUTION!

*Before making road tests, make sure the area is clear of vehicular and pedestrian traffic.*

Make several hard stops from 20 m.p.h. on a dry paved road free of sand and gravel. If the trailer brakes lock and slide, decrease the gain setting on the controller. If they do not slide, slightly increase the gain setting. Adjust the controller just to the point of impending brake lockup and wheel skid.

*Note: Minimum vehicle stopping distances are achieved when wheels approach lock up. Brake lock up should be avoided as it results in poor vehicle stability and control. Depending on load, brake type, wheels and tires, not all trailer brakes are capable of wheel lockup.*

If the controller is applying the trailer brakes before the tow vehicle brakes, then the controller level adjustment should be adjusted so the trailer brakes come on in synchronization with the tow vehicle brakes. For proper braking performance, it is recommended that the controller be adjusted to allow the trailer brakes to come on just slightly ahead of the tow vehicle brakes. When proper synchronization is achieved there will be no sensation of the trailer “jerking” or “pushing” the tow vehicle during braking.

#### CAUTION!

*Do not adjust this control outside the parameters outlined by the manufacturers instructions.*

# Component Identification

ITEM	QTY.	PART NO.	DESCRIPTION
1	1	10713	BREAKAWAY SWITCH
2	1	11191	3" TOWING EYE
3	3	11989	CLEARANCE & MARKER LAMP
4	3	12034	GROMMET (FOR CLEARANCE LAMP)
5	2	12709	CLEARANCE LIGHT REFLECTOR, RED
6	2	12710	CLEARANCE LIGHT REFLECTOR, YLW
7	4	12711	CLEARANCE LIGHT GROMMET KIT
8	4	12838	SEALED ASY-STOP, TURN / TAIL LIGHT
9	16	15221	LUG NUT 9/16-18 60°
10	1	17079	BATTERY BOX
11	1	17080	SEALED RECHARGEABLE BATTERY
12	1	18743	JACK ASSY 10,000 LB
13	4	18804	HEAVY DUTY HITCH PIN-5/8 x 4-1/2
14	1	24897	LICENSE PLATE LAMP, TRUCK-LITE
15	2	30930	SAFETY CHAIN 3/8 SYS.4 3/8 CLEV/IS HK
16	1	46948	DECAL, NATM COMPLIANCE
17	1	46949	DECAL, NATM COMBO PNTLE EB
18	1	46953	DECAL, TRAILER WARNING COMBO
19	2	48206	SAFETY STRIP
20	3	49673	B2598H SPRING LATCH
21	2	52383	STABILIZER JACK W.A.
22	4	61154	SADDLE W.A.

ITEM	QTY.	PART NO.	DESCRIPTION
23	1	61191	DECAL, OVERLOAD HAZARD
24	1	61353	TIRE & LOADING INFORMATION LABEL
25	6	63031	SKID TAPE, 46 x 8
26	1	64120	TURNTABLE BEARING
27	4	65778	SADDLE BUSHING, MODIFIED
28	1	67204	LATCH ASSEMBLY
29	1	67652	HANDLE W.A.
30	1	67653	CHANNEL
31	2	68266	REEL LOCK ASSY
32	2	70097	T&W ASSY ST235/80R16 LRE (WHITE WHEEL)
33	1	70104	TRAILER W.A.
34	1	70114	REEL FRAME ASSY
35	1	70115	REEL FRAME W.A.
36	2	70118	SPINDLE BAR W.A.
37	2	70717	LADDER W.A.
38	4	70719	CRUSH HAZARD WARNING LABEL
39	2	70723	STOP BAR
40	4	70724	LADDER GUIDE GUSSET
41	1	70725	SAFETY STRIP, LEFT FENDER
42	1	70726	SAFETY STRIP, RIGHT FENDER
43	1	70727	WIRE HARNESS ASSY
44	1	X-33267	SAFETY CHAIN ANCHOR
45	2	X-37017	PLAIN MUD GUARD 11 X 12

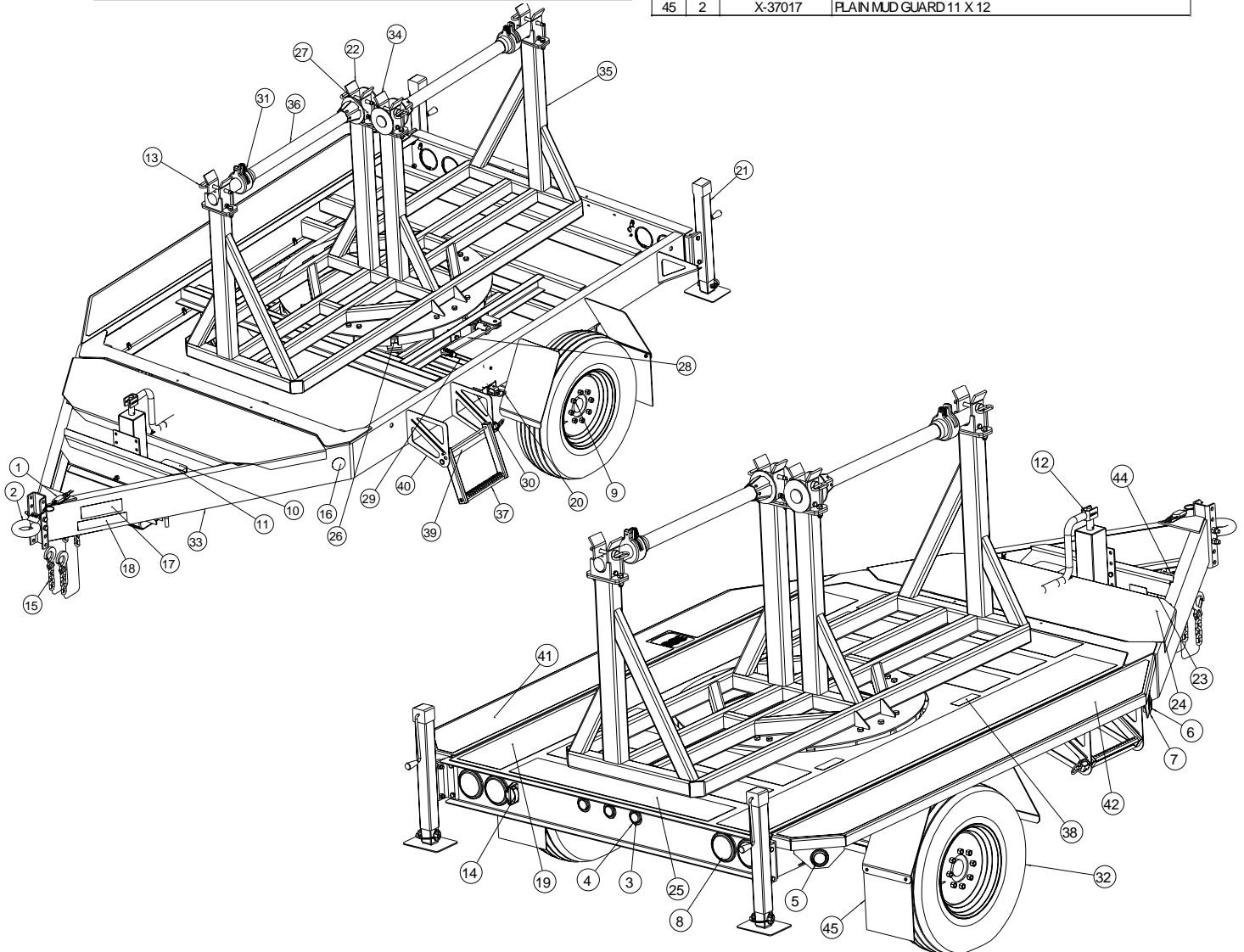

# Hub Components

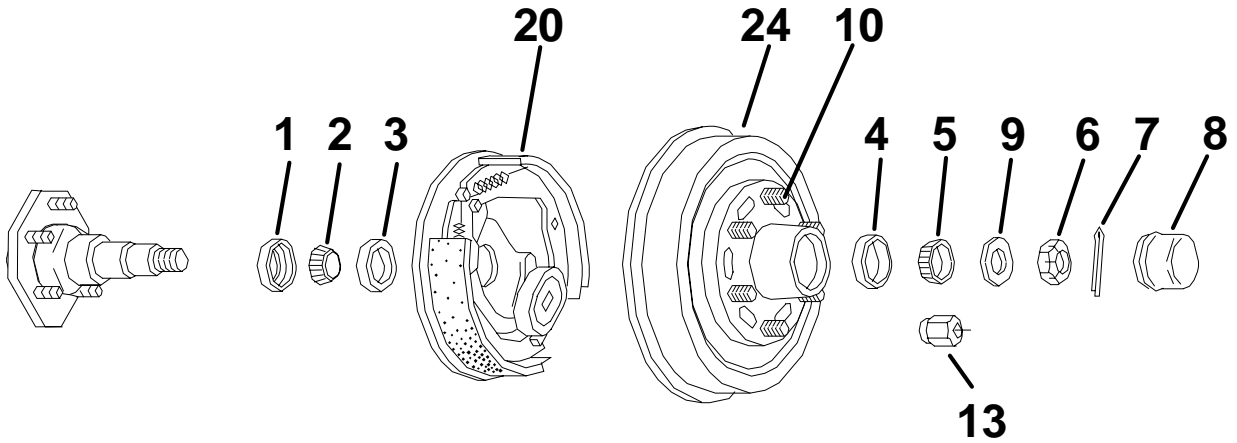

## GREASE LUBE PARTS

Item	Part No.	Description
1	010-036-00	Grease Seal
2	031-030-02	25580 Inner Bearing Cone
3	031-030-01	25520 Inner Bearing Cup
4	031-032-01	LM67010 Outer Bearing Cup
5	031-032-02	LM67048 Outer Bearing Cone
4	031-029-01	15245 Outer Bearing Cup
5	031-029-02	15123 Outer Bearing Cone
6	006-176-00	Spindle Nut
7	019-002-00	Cotter Pin
8	021-001-00	Grease Cap
9	005-023-00	Spindle Washer

## 12 X 2 BRAKES

Item	Part No.	Description
20	023-105-00/023-106-00	LH/RH DXQ Electric

## HUBS

Item	Part No.	Description	Bolt Circle
<i>Hubs and Drums</i>			
24	008-201-05	½" Stud	6 on 5.50
24	008-201-09	½" Stud 15123 bearing	6 on 5.50

## STUDS & WHEEL NUTS

Item	Part No.	Description
10	007-122-00	½-20 Press-in Stud
13	006-080-00	½-20 60° Cone Nut

# 12" x 2" Brake Components

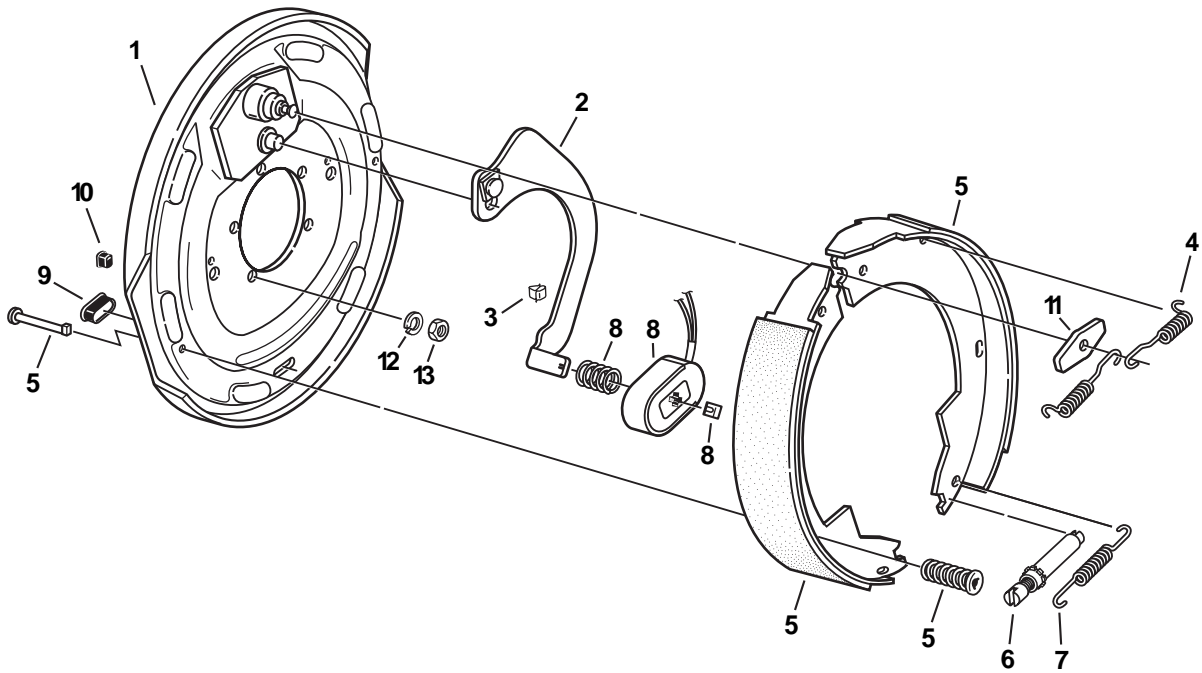

## DXQ ELECTRIC BRAKE 6000#

Item	Part No.	Qty/Brk	Description
0	023-105-00	1	LH Complete Brake Assembly
0	023-106-00	1	RH Complete Brake Assembly
1	036-089-05	1	Backing Plate Assembly
2	047-107-00	1	LH Actuating Lever Arm Assembly
2	047-108-00	1	RH Actuating Lever Arm Assembly
3	027-005-00	2	Wire Clip
4	046-009-00	2	Retractor Spring
5	K71-048-00	1	Shoe and Lining Kit containing: 1 #040-044-00 Primary S&L 1 #040-045-00 Secondary S&L 2 #049-011-00 Shoe Hold Down Pin #2 2 #046-077-00 Shoe Hold Down Spring & Cup
6	043-004-00	1	Adjuster Assembly
7	046-018-00	1	Adjusting Screw Spring
8	K71-105-00	1	Magnet Kit containing: 1 #042-099-01 Magnet (white wire) 1 #027-009-00 Magnet Clip 1 #046-080-00 Magnet Spring
9	046-007-00	1	Adjuster Slot Plug
10	046-016-00	1	Wire Grommet
11	005-067-00	1	Anchor Post Washer
12	005-004-00	5	Lockwasher
13	006-010-00	5	Brake Mounting Nut

**These brakes are rated to a maximum capacity of 6000 lbs.**

## 6,000 # Suspension Components

No.	Part No.	Qty Per Trailer.	Description
NS	70125	1	Complete Axle Assembly
1	27066	2	Front Hanger
4		4	U-Bolt
5	27067	2	Rear Hanger
6		2	Spring Seat
7		8	U-Bolt Nut
8	72-032-00	2	7,500# Spring
9	15381	2	Spring Eye Bolt
10	08095	2	9/16" Locknut
12	15220	2	Keeper Bolt
11	15219	2	Keeper Locknut

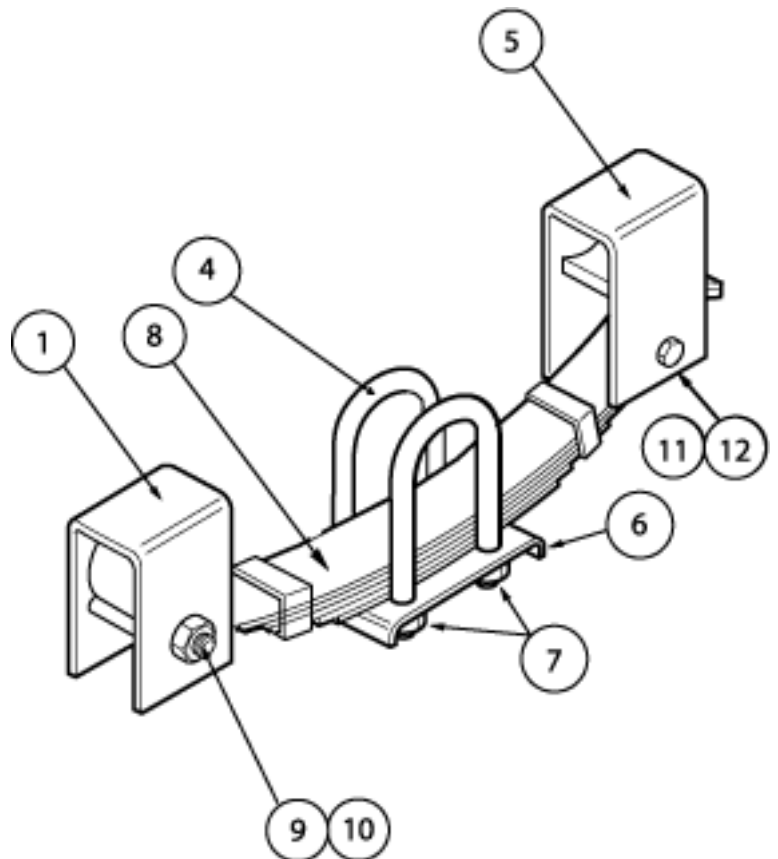

## Lubrication of Body Components



MGS recommends using a lithium base, high pressure grease

Lubricate all pivot points in the latch assembly and lubricate the grease zerk fitting accessed through the hole in the longitudinal crossmember shown in photo



Turntable is to be lubricated via multiple grease zerks on the diameter of the bearing. minimum interval is 3 months. Do not use calcium or sodium based lubricants.

If welding is performed on trailer, never attach ground in a manner that current can flow through the turntable. Damage to the bearing will result



Grease step glidepin and latch

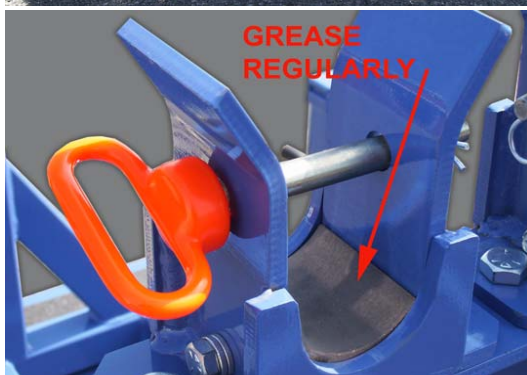

Grease spindle bushing regularly

# Electric Brakes

## *Maintenance*

### Self-Adjusting Mechanism for 12¼" Electric Brakes

Designs prior to 10/96 only adjust the brake shoes outward during a reverse stop. The mechanism consisted of an adjuster screw, an adjuster lever, an adjuster lever, pivot pin, an adjuster return spring (blue or white), a cable, and a cable anchor (also known as shoe guide plate). On one end, the adjuster lever pivots on the pivot pin that is pressed into the shoe web. The other end of the adjusting lever engages the teeth of the star wheel cable guide that is staked into the secondary shoe web. When a reverse stop is made and there is need for shoe adjustment, the secondary shoe moves away from the anchor post pulling on the cable. Since the cable is anchored on the top end and hooked on the lever on the other end, the lever is pulled upward turning the star wheel and thus making increasing the diameter of the shoes. When the brake is released and the secondary shoe returns to the anchor post, the adjuster return spring returns the lever and cable to their starting position.

Forward self adjust brakes released after 10/96 adjusts the brakes on both forward and reverse stops. The reverse stop adjustment is the same as the previous design. Forward brake adjustment occurs when the modified shoe guide plate (cable anchor) rotates when engaged by the pin that is staked in the rotating magnet lever arm. A modification to the anchor post prevents the shoe guide plate from being clamped tight as in the previous design. The rotating shoe guide plate (cable anchor) pulls the cable that lifts the adjuster lever to turn the adjuster star wheel. After the brake shoes obtain proper adjustment, there is insufficient movement of the magnet lever arm to cause enough rotation of the shoe guide to pull the cable to engage the next tooth on the adjuster star wheel. When the linings have worn sufficiently, the increased rotation of the lever arm and shoe guide plate will cause the adjuster lever to engage the next tooth on the adjuster and adjust the brake continuing to maintain a superior level of adjustment.

### **Manual Brake Adjustment**

If your brakes do not have automatic adjustment, the following procedure must be followed:

Brakes should be adjusted (1) after the first 200 miles of operation when the brake shoes and drums have “seated,” (2) at 3000 mile intervals, (3) or as use and performance requires. The brakes should be adjusted in the following manner:

1. Jack up trailer and secure on adequate capacity jack stands. Follow trailer manufacturers recommendations for lifting and supporting the unit. Check that the wheel and drum rotate freely.
2. Remove the adjusting hole cover from the adjusting slot on the bottom of the brake backing plate.
3. With a screwdriver or standard adjusting tool, rotate the starwheel of the adjuster assembly to expand the brake shoes. Adjust the brake shoes out until the pressure of the linings against the drum makes the wheel very difficult to turn.

*Note: With drop spindle axles, a modified adjusting tool with about an 80° angle should be used. Sears Craftsman #4736 or K-D #295 are recommended.*

4. Then rotate the starwheel in the opposite direction until the wheel turns freely with a slight lining drag.
5. Replace the adjusting hole cover and lower the wheel to the ground.
6. Repeat the above procedure on all brakes.

### **CAUTION!**

*Never crawl under your trailer unless it is resting on properly placed jack stands*

Follow the trailer manufacturers recommendations for lifting and supporting the unit. Do not lift or place supports on any part of the suspension system.

# General Maintenance

## Brake Cleaning and Inspection

Your trailer brakes must be inspected and serviced at yearly intervals or more often as use and performance requires. Magnets and shoes must be changed when they become worn or scored thereby preventing adequate vehicle braking.

Clean the backing plate, magnet arm, magnet, and brake shoes. Make certain that all the parts removed are replaced in the same brake and drum assembly. Inspect the magnet arm for any loose or worn parts. Check shoe return springs, hold down springs, and adjuster springs for stretch or deformation and replace if required. Check freedom of shoes. An acutated lever arm should snap back with shoes when released.

### CAUTION!

*ASBESTOS DUST HAZARD! Since some brake shoe friction materials contain asbestos, certain precautions need to be taken when servicing brakes:*

1. Avoid creating or breathing dust.
2. Avoid machining, filing or grinding the brake linings.
3. Do not use compressed air or dry brushing for cleaning. (Dust can be removed with a damp brush.)

## Brake Lubrication

Before reassembling, apply a light film of Lubriplate or similar grease, or anti-seize compound on the brake anchor pin, the actuating arm bushing and pin, and the areas on the backing plate that are in contact with the brake shoes and magnet lever arm. Apply a light film of oil on the actuating block mounted on the actuating arm.

### CAUTION!

*Do not get grease or oil on the brake linings, drums or magnets.*

## Magnets

Your electric brakes are equipped with high quality electromagnets that are designed to provide the proper input force and friction characteristics. Your magnets should be inspected and replaced if worn unevenly or abnormally. A straightedge should be used to check wear.

Even if wear is normal as indicated by your straightedge, the magnets should be replaced if any part of the magnet coil has become visible through the friction material facing of the magnet. It is also recommended that the drum armature surface be re-faced when replacing magnets. Magnets should also be replaced in pairs - both sides of an axle.

Use only genuine Dexter replacement parts when replacing your magnets.

## Shoes and Linings

A simple visual inspection of your brake linings will tell if they are usable. Replacement is necessary if the lining is worn (to within  $\frac{1}{16}$ " or less), contaminated with grease or oil, or abnormally scored or gouged. It is important to replace both shoes on each brake and both brakes of the axle assembly

# *Troubleshooting*

Most electric brake malfunctions that cannot be corrected by either brake adjustments or synchronization adjustments can generally be traced to electrical system failure. Mechanical causes are ordinarily obvious, i.e. bent or broken parts, worn out linings or magnets, seized lever arms or shoes, scored drums, loose parts, etc. Voltmeter and ammeter are essential tools for proper troubleshooting of electric brakes.

## **How to Measure Voltage**

System voltage is measured at the magnets by connecting the voltmeter to the two magnet lead wires at any brake. This may be accomplished by using a pin probe inserted through the insulation of the wires dropping down from the chassis or by cutting the wires. The engine of the towing vehicle should be running when checking the voltage so that a low battery will not affect the readings.

Voltage in the system should begin at 0 volts and, as the controller bar is slowly actuated, should gradually increase to about 12 volts. This is referred to as modulation. No modulation means that when the controller begins to apply voltage to the brakes it applies an immediate high voltage, which causes the brakes to apply instantaneous maximum power.

The threshold voltage of a controller is the voltage applied to the brakes when the controller first turns on. The lower the threshold voltage the smoother the brakes will operate. Too high of a threshold voltage (in excess of 2 volts as quite often found in heavy duty controllers) can cause grabby, harsh brakes.

## **How to Measure Amperage**

System amperage is the amperage being drawn by all brakes on the trailer. The engine of the towing vehicle should be running when checking amperage.

One place to measure system amperage is at the BLUE wire of the controller which is the output to the brakes. The BLUE wire must be disconnected and the ammeter put in series into the line. System amperage draw should be as noted in the following table. Make sure your ammeter has sufficient capacity and note polarity to prevent damaging your ammeter.

If a resistor is used in the brake system, it must be set at zero or bypassed completely to obtain the maximum amperage reading. Individual amperage draw can be measured by inserting the ammeter in the line at the magnet you want to check. Disconnect one of the magnet lead wire connectors and attach the ammeter between the two wires. Make sure that the wires are properly reconnected and sealed after testing is completed.

By far, the most common electrical problem is low or no voltage and amperage at the brakes. Common causes of this condition are:

1. Poor electrical connections; bad ground
2. Open circuits
3. Insufficient wire size
4. Broken wires
5. Blown fuses (Fusing of brakes is not recommended.)

6. Improperly functioning controllers or resistors

Another common electrical problem is shorted or partially shorted circuits (indicated by abnormally high system amperage). These are occasionally the most difficult to find. Possible causes are:

1. Shorted magnet coils
2. Defective controllers
3. Bare wires contacting a grounded object

Finding the system short is a matter of isolation. If the high amperage reading drops to zero by unplugging the trailer, then the short is in the trailer. If the amperage reading remains high with all the brake magnets disconnected, the short is in the trailer wiring.

All electrical troubleshooting procedures should start at the controller. Most complaints regarding brake harshness or malfunction are traceable to improperly adjusted or non-functioning controllers. See your controller manufacturer's data for proper adjustment and testing procedures. If the voltage and amperage is not satisfactory, proceed on to the connector and then to the individual magnets to isolate the problem source. 12 volts output at the controller should equate to 10.5 volts minimum at each magnet. Nominal system amperage at 12 volts with cold magnets, system resistor at zero and controller at maximum gain should be as detailed in the following chart:

**Magnet Amperes Chart**

<b>Brake Size</b>	<b>Amps/Magnet</b>	<b>Two Brakes</b>	<b>Four Brakes</b>	<b>Six Brakes</b>
12 <sup>1</sup> / <sub>4</sub> x 3 <sup>3</sup> / <sub>8</sub>	3.0	6.0	12.0	18.0
12 <sup>1</sup> / <sub>4</sub> x 4	3.0	6.0	12.0	18.0
12 <sup>1</sup> / <sub>4</sub> x 5	3.0	6.0	12.0	18.0

## Trailer Warranty Information



Your new trailer is warranted by MGS Inc. Please contact MGS Inc. for information and assistance with warranty related issues before attempting to repair any component of the trailer. Making repairs without authorization from MGS may void your warranty.

MGS inc.  
178 Muddy Creek Church Rd.  
Denver, PA 17517  
1-800-952-4228  
[www.mgsincorporated.com](http://www.mgsincorporated.com)



## MGS 1-Year Limited Warranty

MGS Incorporated (Seller) hereby warrants, for a period of **ONE** years from the date of purchase, to the first buyer- purchaser (Purchaser) of a **MGS Trailer** manufactured by Seller (Product) that the Product shall be free from defects in material or workmanship, provided timely notice of any claim on this warranty is given to Seller by Purchaser. *Notice of any warranty claim shall be untimely if written notice of such claim is not given to Seller in writing within fifteen (15) days from the date Buyer has discovered or, with the exercise of reasonable diligence, would have discovered any such defect in material or workmanship giving rise to such warranty claim. Any claim for breach of warranty which is not timely made shall be deemed waived by purchaser.*

Provided that a timely notice of a warranty claim is made for a defect in material or workmanship arising during the warranty period. Seller shall repair or replace any defective Product or portion thereof, or, at its option, may refund the purchase price for the Product. All decisions concerning whether a Product or any portion thereof is defective and whether said defects should be repaired or the Product replaced, and the manner, method and extent of such repairs, shall be within the sole discretion of Seller. Any alteration or repair to a Product or any portion thereof made by Purchaser without the prior written approval of Seller shall be done at Buyer's own risk and expense and shall invalidate this warranty.

Seller makes no warranty in connection with any components provided with the Product subject to a separate manufacturer's warranty and any claim relating to such goods shall lie exclusively against the manufacturer of such goods.

This warranty is made in lieu of all other warranties, express, implied or statutory. **Seller expressly disclaims any warranty or merchantability or warranty of fitness for a particular purpose or use.**

The express warranty provided herein shall be Purchaser's sole and exclusive remedy for any defects in material or workmanship relating to Product. Under no circumstance shall Seller be liable to Purchaser or any other person for lost profits, additional expenses incurred in repairing or replacing the Product or any other special, incidental, indirect or consequential losses of damages of any kind. Purchaser shall have no claim under this warranty for ordinary wear and tear or for abuse, misuse, improper installation or maintenance or alteration of or repairs to the Product unless such repairs have been authorized in writing by Seller prior to said repair.

**Notice of any claim under this warranty must be made in writing and sent to Seller by certified mail, return receipt requested addressed to: MGS Incorporated, Sales Department, 178 Muddy Creek Church Road, Denver, PA 17517.**



If you believe that your vehicle has a defect which could cause a crash or could cause injury or death, you should immediately inform the National Highway Traffic Safety Administration (NHTSA) in addition to notifying MGS Inc.

If NHTSA receives similar complaints, it may open an investigation, and if it finds that a safety defect exists in a group of vehicles, it may order a recall and remedy campaign. However, NHTSA cannot become involved in individual problems between you, your dealer, or MGS Inc.

To contact NHTSA, you may either call the Auto Safety Hotline toll-free at 1-800-424-9393 (or 202-366-0123) or write to: NHTSA, U.S. Department of Transportation, 400 7th street, SW, NSA-11, Washington, DC 20590. You can also obtain other information about motor vehicle safety from the Hotline.