

Operator's Manual



McElroy Manufacturing, Inc.

The leader by design.

www.mcelroymfg.com

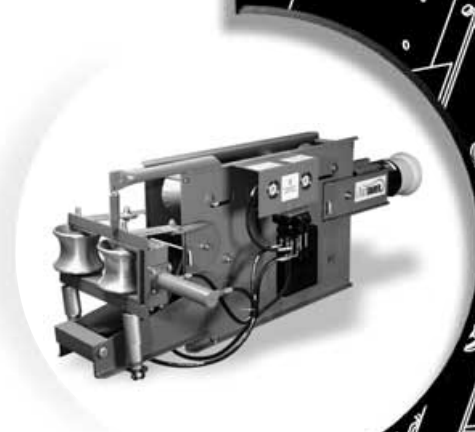

6" IPS Pipe Preparation Machine

LINE TAMER[™]

Patent No. 5,676,009

Manual: LT0104 Revision: B 5/02

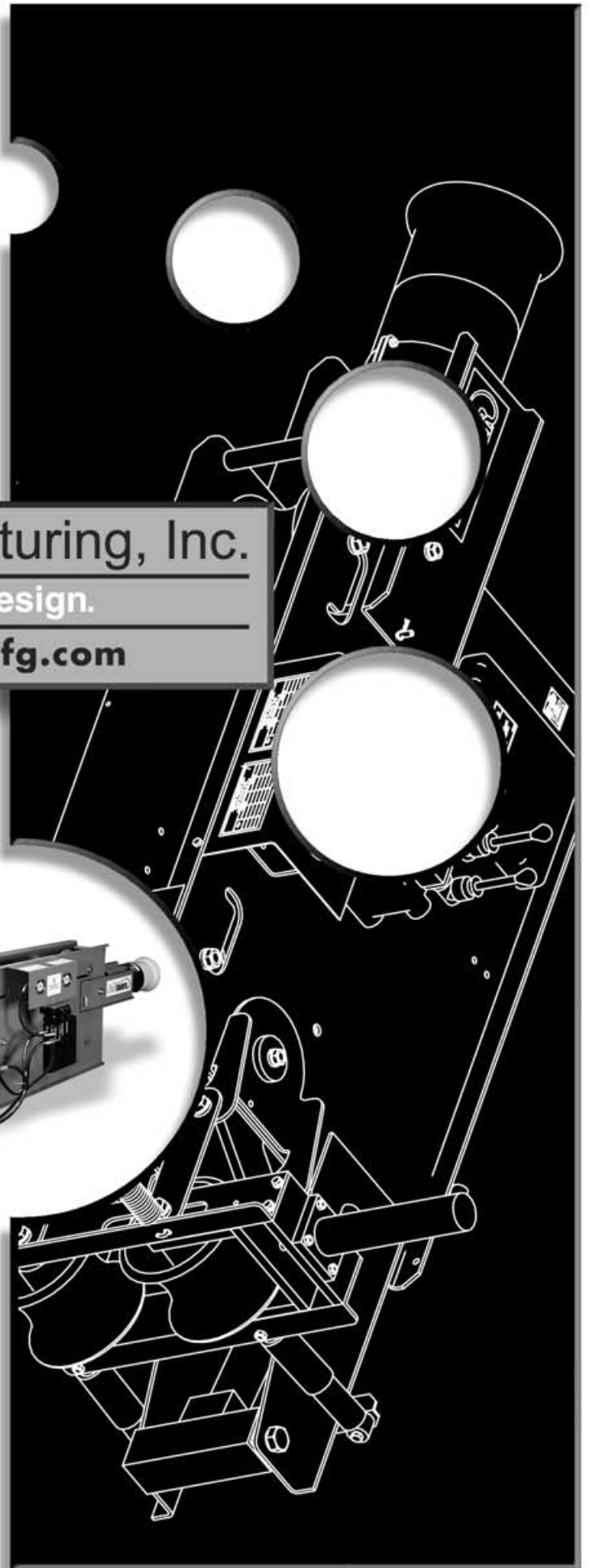



Introduction



Thank you for purchasing this McElroy product.

The McElroy LineTamer™ is designed to remove coil set and reround coiled pipe for easier fusion and to minimize the possibility of dangerous uncontrolled pipe recoil. The LineTamer consists of a straightening unit and a rerounding unit which prepares 3" to 6", high and medium density coiled polyethylene pipe for installation. With reasonable care and maintenance, this machine will give years of satisfactory service.

Before operating this machine, please read this manual thoroughly, and keep a copy with the machine for future reference. This manual is to be considered part of your machine.



PHO1997-12-15-00

TX00569-7-19-95

California Proposition 65 Warning

Engine exhaust from this product contains chemicals known to the State of California to cause cancer, birth defects, or other reproductive harm.

World Class Training

This manual is intended as a guide only and does not take the place of proper training by qualified instructors. The information in this manual is not all inclusive and can not encompass all possible situations that can be encountered during various operations.

McElroy Manufacturing, Inc., offers advanced training classes to enhance efficiency, productivity, safety and quality. Training is available at our facility or on-site at your location. Call (918) 836-8611

TX01083-12-10-96



PH00917-5-16-98



Warranty



LIMITED WARRANTY

McElroy Manufacturing, Inc. guarantees this product to the original purchaser against workmanship and material defects for one (1) year from date of shipment, with the exception of purchased items (such as electronic devices, pumps, switches, tires, engines, etc.), in which case that manufacturer's warranty applies. This warranty does not apply to any product or component which has been repaired or altered by anyone other than McElroy Manufacturing, Inc., or has become damaged due to misuse, negligence or casualty, or has not been operated or maintained according to McElroy Manufacturing, Inc.'s printed instructions and warnings.

Materials returned to McElroy Manufacturing, Inc. for warranty work, repair, etc., **must have a Return Material Authorization (RMA) number**, and be so noted on the package at time of shipment. This number may be obtained by calling (918) 836-8611.

If seller's review indicates that warranty applies, the defective product will be repaired or replaced and returned to purchaser F.O.B. Tulsa, Oklahoma.

McElroy Manufacturing, Inc. is not responsible or liable for loss of any sort including incidental and consequential damages.

McElroy Manufacturing, Inc. specifically disavows any other representations as to warranty or liability, related to the condition or use of the product.

For assistance, inquiries shall be directed to McElroy Manufacturing, Inc., P.O. Box 580550, 833 North Fulton, Tulsa, Oklahoma 74158-0550, (918) 836-8611, Fax No. (918) 831-9285

(Copy information listed on the Warranty Card for your records)

LineTamer™

Serial No. _____

Model No. _____

DISCLAIMER OF LIABILITY

McElroy Manufacturing, Inc. accepts no responsibility of liability for fusion joints. Operation and maintenance of the product is the responsibility of others. We recommend qualified joining procedures be followed when using McElroy fusion equipment.

McELROY MAKES NO OTHER WARRANTY OF ANY KIND WHATEVER, EXPRESS OR IMPLIED; AND ALL IMPLIED WARRANTIES OF MERCHANTABILITY AND FITNESS FOR A PARTICULAR PURPOSE WHICH EXCEED THE AFORESTATED OBLIGATION ARE HEREBY DISCLAIMED BY McELROY.

PRODUCT IMPROVEMENT

McElroy Manufacturing, Inc. reserves the right to make any changes in or improvements on its products without incurring any liability or obligation to update or change previously sold machines and/or the accessories thereto.

TERMS AND CONDITIONS

LineTamers are net 30 days - Subject to credit approval. A carrying charge of 1-1/2% per month computed from invoice date will apply to invoices not paid within 30 days.

McElroy Manufacturing, Inc. must be notified of any discrepancy in shipment, order, and/or invoice within 10 days after receipt.

Freight is F.O.B. Tulsa, Oklahoma - usually motor freight collect or UPS unless otherwise specified.

Prices are subject to change without notice.

Minimum order is \$50.00.

**Register Online:
www.mcelroymfg.com**



Table of Contents



Equipment Safety

Safety Alerts	1-1
Read and Understand	1-1
General Safety	1-2
Wear Safety Equipment	1-2
Gas Powered Units	1-2
Fuel Handling	1-3
Carbon Monoxide	1-3
Keep Personnel Away	1-3
Cutting Steel Bands	1-4
Coiled Pipe Safety	1-4
Units with Hydraulics	1-5
Operator's Seat	1-5

Overview

Usage Options	2-1
Stringing Pipe	2-1
Stringing and Planting Pipe	2-1
Stringing and Plowing Pipe	2-2
Straightening Pipe for Relining	2-2
Straightening Pipe for Directional Boring	2-2
Hydraulic Power Unit	2-3
Fuel Valve	2-3
Engine Control Lever	2-3
Hydraulic Fluid	2-3
Hydraulic Controls	2-4
Pressure Gauges	2-4
Rerounding Rollers	2-4
Straightening Rollers	2-4

Transporting

Secure Pipe Before Transporting	3-1
Lock Machine	3-1
Read Before Towing Trailer	3-2

Preparation for Pulling

Connect Trailer	4-1
Load Coil	4-1
Securing Pipe when using a Reel	4-1
Unlocking Machine	4-1
Positioning Pipe Payout	4-2
Rerounder Rollers	4-2
Straightening Rollers	4-3
Check Hydraulic Fluid	4-3

COPYRIGHT © 2000

McELROY MANUFACTURING, INC.

Tulsa, Oklahoma, USA

All rights reserved

All product names or trademarks are property of their respective owners. All information, illustrations and specifications in this manual are based on the latest information available at the time of publication. The right is reserved to make changes at any time without notice.



Table of Contents



Operation

Read and Understand	5-1
Pulling Force Limitations	5-1
Before Starting Operation	5-2
Start Engine	5-2
Cutting Steel Bands	5-2
Cutting Plastic Bands	5-2
Pipe Threading Roller Valve	5-3
Loading Pipe in LineTamer™	5-3
Pressure Settings	5-4
Rerounder Pressure	5-4
Straightener Pressure	5-4
Monitor Pressure	5-5
Precautions	5-5
End of Coil with Pipe Secured	5-5

Maintenance

Preventative Maintenance	6-1
Washing the Machine	6-1
Check Hydraulic Fluid	6-1
Grease Bearing and Sleeves	6-1
Grease Moving parts	6-2

Hydraulic Fluids

Hydraulic Fluids	7-1
----------------------------	-----

Specifications

LineTamer	8-1
Hydraulic Power Unit	8-1



WR00051-11-30-92

Safety Alerts



This hazard alert sign appears in this manual. When you see this sign, carefully read what it says. **YOUR SAFETY IS AT STAKE.**

You will see the hazard alert sign with these words: **DANGER**, **WARNING**, and **CAUTION**.



Indicates an imminently hazardous situation which, if not avoided, will result in death or serious injury.



Indicates a potentially hazardous situation which, if not avoided, could result in death or serious injury.



Indicates a hazardous situation which, if not avoided, may result in minor or moderate injury.

In this manual you should look for two other words: **NOTICE** and **IMPORTANT**.

NOTICE: can keep you from doing something that might damage the machine or someone's property. It may also be used to alert against unsafe practices.

IMPORTANT: can help you do a better job or make your job easier in some way.

TX00030-12-1-92



Read and Understand

Do not operate this equipment until you have carefully read, and understand the "Safety" and "Operation" sections of this manual, and all other equipment manuals that will be used with it.

Your safety and the safety of others depends upon care and judgment in the operation of this equipment.

Follow all applicable federal, state, local, and industry specific regulations.

McElroy Manufacturing, Inc. cannot anticipate every possible circumstance that might involve a potential hazard. The warnings in this manual and on the machine are therefore not all inclusive. You must satisfy yourself that a procedure, tool, work method, or operating technique is safe for you and others. You should also ensure that the machine will not be damaged or made unsafe by the method of operation or maintenance you choose.



TX00031-12-8-92

WR00052-12-1-92



Equipment Safety



General Safety

Safety is important. Report anything unusual that you notice during set up or operation.

LISTEN for thumps, bumps, rattles, squeals, air leaks, or unusual sounds.

SMELL odors like burning insulation, hot metal, burning rubber, hot oil, or natural gas.

FEEL any changes in the way the equipment operates.

SEE problems with wiring and cables, hydraulic connections, or other equipment.

REPORT anything you see, feel, smell, or hear that is different from what you expect, or that you think may be unsafe.



SAFE1ST12-22-92

TX00114-4-22-93

Wear Safety Equipment

Wear a hard hat, safety shoes, safety glasses, and other applicable personal protective equipment.

Remove jewelry and rings, and do not wear loose-fitting clothing or long hair that could catch on controls or moving machinery.

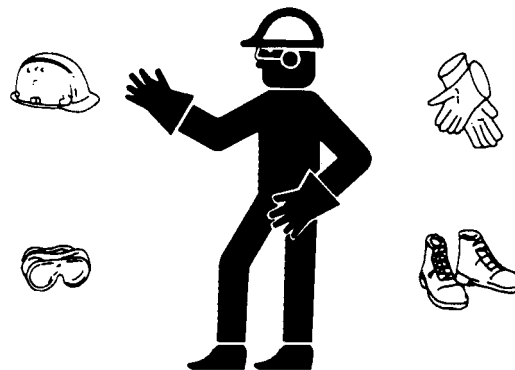

WRC0053-12-2-92

TX00032-4-7-93

Gas Powered Units

⚠ DANGER Gasoline engines will cause explosions when operated in a hazardous environment. Do not operate gas powered machines in a hazardous environment.

Do not place flammable substances near the engine while it is operating.

A spark arrester is available as an optional part for this engine. It is illegal in some areas to operate an engine without a spark arrester. Check local laws and regulations before operating.



WRC0080-4-12-93

TX00955-5-14-96



Fuel Handling

⚠ DANGER Gasoline and diesel fuel are extremely flammable and their vapors will explode if ignited.

Do not fill the fuel tank while the engine is hot or running, as spilled fuel could ignite.

Refuel in a well ventilated area. Do not smoke or allow flames or sparks in the area where the engine is refueled, or where gasoline is stored.

Do not start the engine near spilled fuel. Wipe up spills immediately.

Make sure the fuel tank cap is closed and properly secured.

Avoid repeated or prolonged contact with skin or breathing of vapor.

TX00953-2-19-97

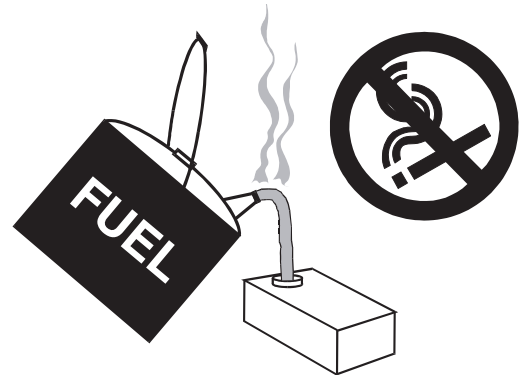

CD00365c-31-97

Carbon Monoxide

⚠ DANGER Engine exhaust gases contain poisonous carbon monoxide. Carbon monoxide can cause severe nausea, fainting and death. Avoid inhaling exhaust fumes and never run the engine in a closed or confined area.

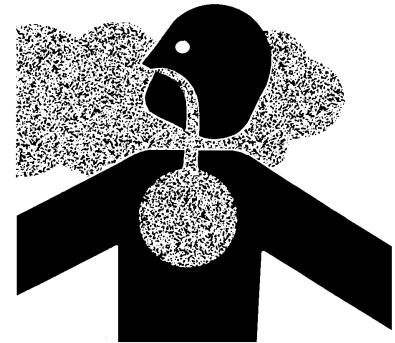

WR00093-5-14-96

TX00954-5-14-96

Keep Personnel Away

⚠ WARNING The rollers in this machine are under hydraulic pressure and can cause severe bodily harm. All personnel must keep hands and body away from moving parts of machine.

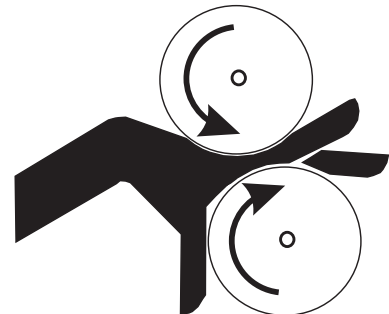

CD00155-8-9-95

TX01601-10-12-98



Equipment Safety



Cutting Steel Bands

⚠ WARNING Coiled pipe can uncoil with considerable force, causing extreme bodily injury if not properly contained. Do not cut the straps around the coil until the coil is contained in a suitable reel trailer or coil cage.

Leave plastic straps on coil. Do not cut.

TX00618-8-31-95



CD00166-8-31-95

Coiled Pipe Safety

When the tail end of the coil unwinds, or when the pipe is being cut, the ends can move suddenly in any direction with great force.

⚠ WARNING Loose ends of coiled pipe can move with great force in any direction. Keep personnel at least 15 feet away.

When pulling pipe through the LineTamer™, personnel and equipment must stay at least 15 feet away from machine and pipe ends.

Cold Weather Conditions

The forceful movement of loose ends of pipe become more pronounced in cold weather and all personnel must be aware for their own safety.

There are practical limits to pulling pipe in cold weather. The ability of the pipe to be straightened and rerounded diminishes.

The LineTamer does not have enough power to properly straighten and reround pipe at lower temperatures. Operation below 32° F is not recommended.

TX01303-3-27-97



CD00165-8-31-95

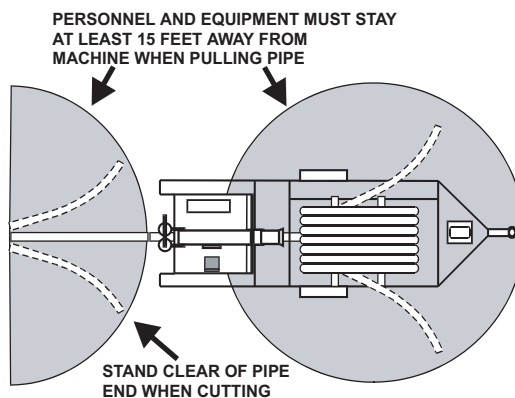

CD00342-12-17-96



Units With Hydraulics

Although the hydraulic pressures in this machine are low compared to some hydraulically operated equipment, it is important to remember that a sudden hydraulic oil leak can cause serious injury, or even be fatal if the pressure is high enough.

WARNING Escaping fluid under pressure can penetrate the skin causing serious injury. Keep hands and body away from pinholes which eject fluid under pressure. Use a piece of cardboard or paper to search for leaks. If any fluid is injected into the skin, it must be immediately removed by a doctor familiar with this type of injury.

NOTICE: Wear safety glasses, and keep face clear of area when bleeding air from hydraulic system to avoid spraying oil into eyes.

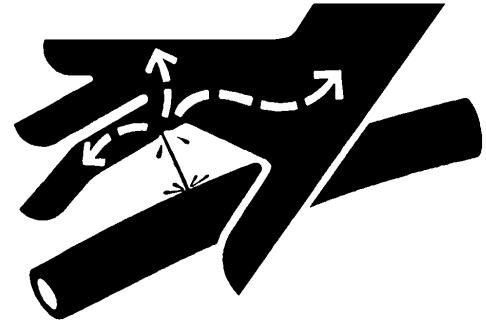

WR00078-4-8-93

TX00110-8-23-95

Operator's Seat

Always operate the machine from the control side with the operator in the control seat. Use the seat belt at all times.

Never stand on the LineTamer™ during operation.

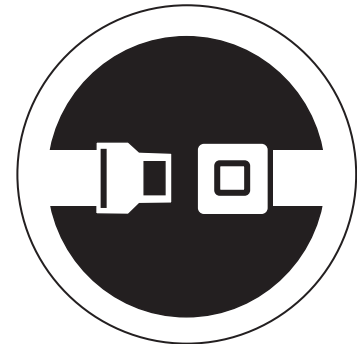

SEAT BELT

CD00167-9-5-95

TX00623-9-5-95



Overview



Usage Options

I: Pulling pipe from LineTamer™ and stringing the pipe on the ground for direct burial (in the trench) or relining an existing pipeline.

II: Pulling LineTamer behind vehicle with pipe reel or cage for stringing out straightened pipe along right of way.

III: Pulling LineTamer behind vehicle with plowing vehicle pulling pipe directly into the ground.

IV: Stationary: LineTamer connected to coil trailer with plowing vehicle pulling a pipe directly into the ground.

V: Stationary: LineTamer connected to coil trailer with pipe being pulled through existing pipe for relining.

VI: Stationary: LineTamer connected to coil trailer with directional boring unit pulling pipe directly into the ground.

TX00570-9-19-95

I: Stringing Pipe

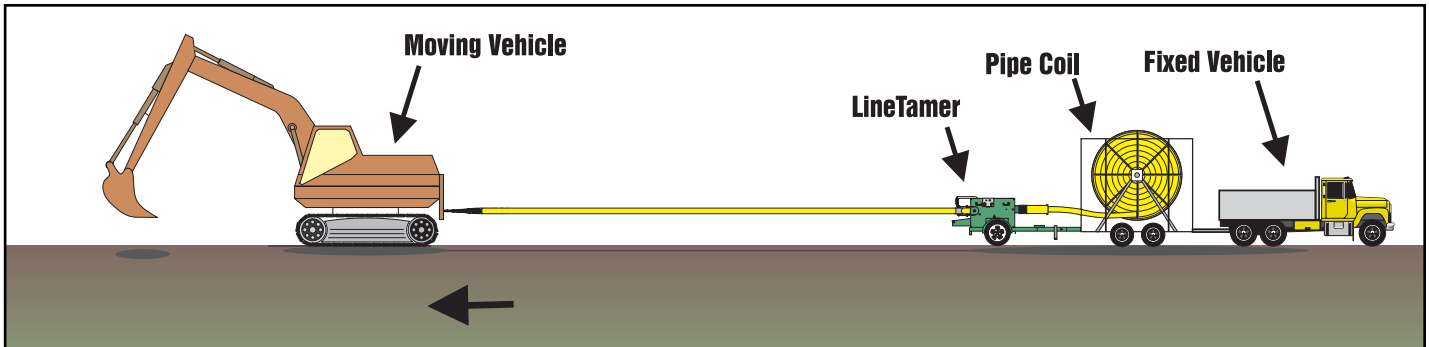

CD001588-3.1-96

II: Stringing Pipe

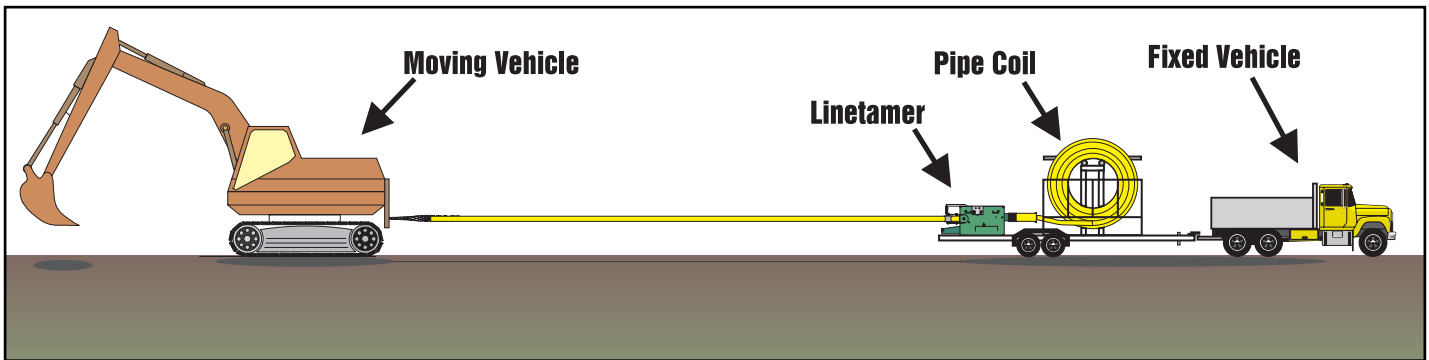

CD001985-1.96

III: Stringing & Planting Pipe

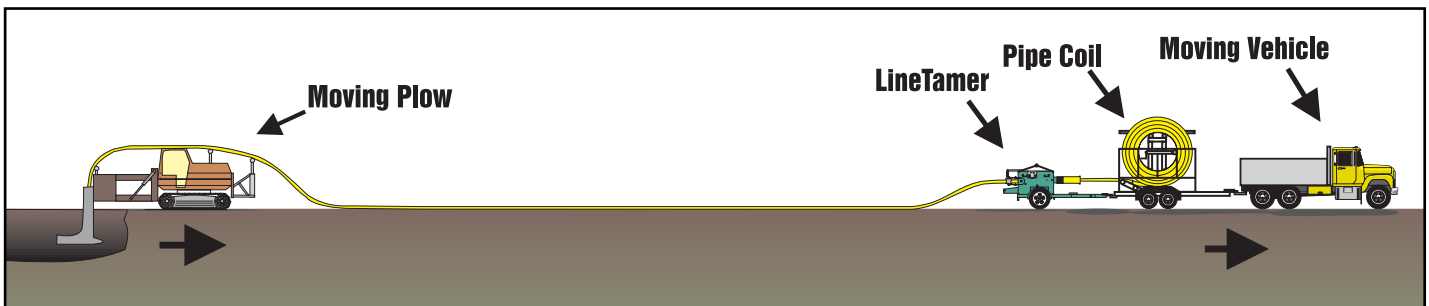

CD001995-1.96



Overview



III: Stringing & Plowing Pipe

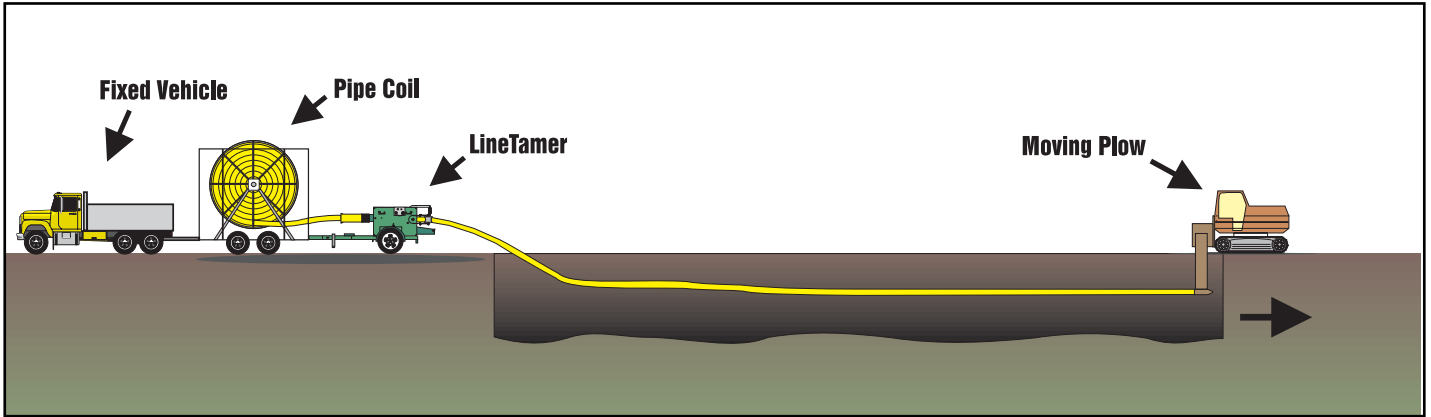

CD00161-8-31-95

IV: Straightening Pipe for Relining

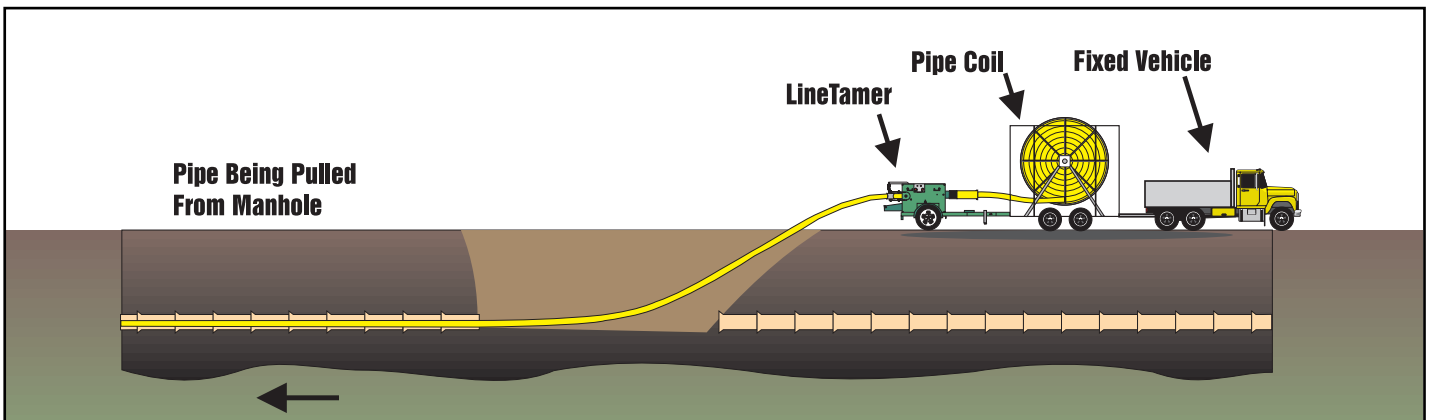

CD00162-8-31-95

V: Straightening Pipe for Directional Boring

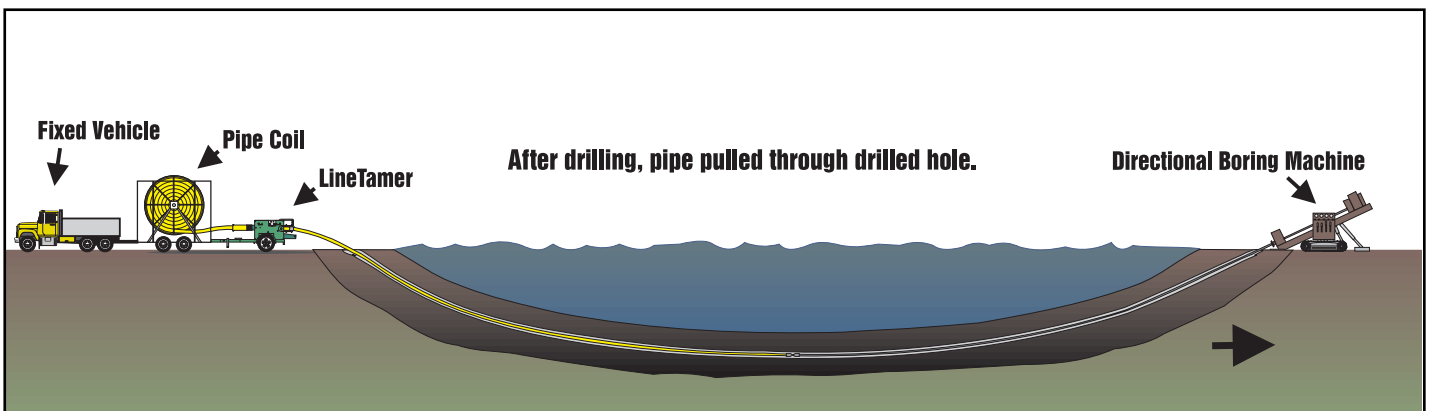

CD00163-8-31-95



Overview



Hydraulic Power Unit

- (A) Hydraulic fluid fill.
- (B) Gasoline fill.
- (C) Starter rope.
- (D) Engine oil check and fill.
- (E) System pressure gauge

The hydraulics are an open center flow system. The pressure relief valve is set at 2500 psi.

TX00957-5-14-96

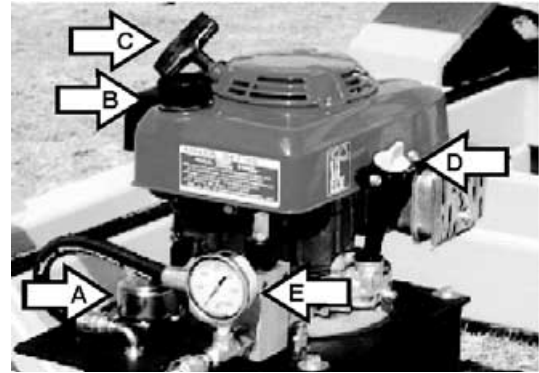

PH008225-13-96

Fuel Valve

The fuel valve should be turned off when transporting the equipment, or when not being used.

Turn the valve control in to turn off. Turn the control out to turn on.

TX00958-5-14-96



PH00823-4-26-96

Engine Control Lever

All the way back to the left, shuts the engine off. All the way forward to the right, is the choke position. Between these two positions, the desired engine speed can be set.

IMPORTANT: Do not use the choke if the engine is warm or the ambient temperature is high.

TX00959-5-14-96

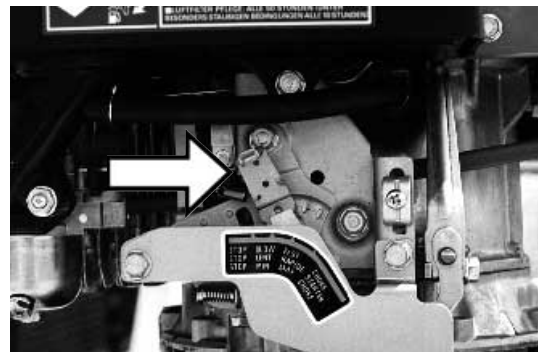

PH00823-4-26-96

Hydraulic Fluid

Check fluid level in reservoir. Proper level is indicated on the sight gauge. If level drops below this point, fill reservoir to the HIGH level on the sight gauge. Refer to the "Hydraulic Fluids" section of this manual for hydraulic oil recommendations.

Never allow dirt or other foreign matter to enter the open tank.

TX00960-5-16-96

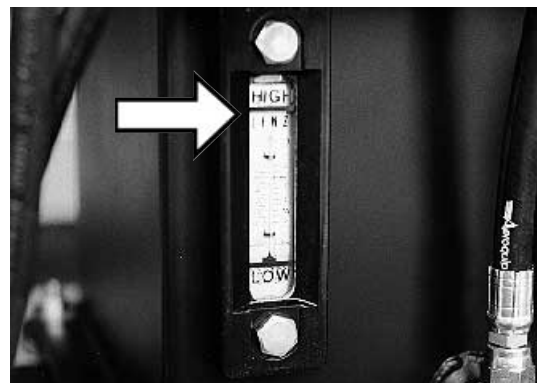

PH00825-5-2-96



Overview



Hydraulic Controls

- (A) Rerounder Pressure Control
- (B) Straightener Pressure Control

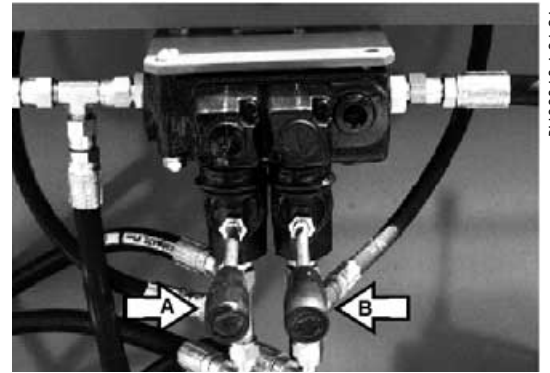

TX01000-6-27-96

PH00868-6-26-96

Pressure Gauges

The pressure gauge on the left indicates pressure on the rerounding rollers.

The pressure gauge on the right indicates pressure on the straightening rollers.



TX00978-6-17-96

PH00855-6-17-96

Rerounding Rollers

Pressure to the rerounding rollers is set by a manually operated control valve.

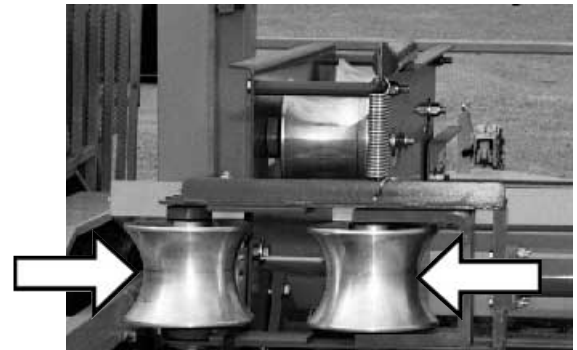

TX00979-6-17-96

PH00854-6-17-96

Straightening Rollers

Pressure to the straightening rollers is set by a manually operated control valve.

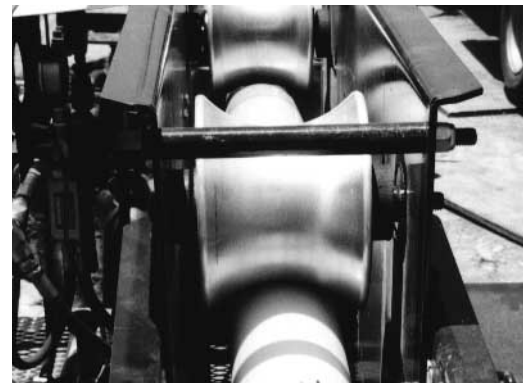

TX00980-6-17-96

PH00471-8-9-95



Transporting



Secure Pipe Before Transporting

The coil of pipe should be secured in the trailer before transporting. Use locking straps or similar means to secure the coil to itself as well as the trailer frame. This will prevent damage to the pipe and trailer from shifting loads at trailering speeds.

If the LineTamer™ is installed on the same trailer that holds the pipe coil, pipe from the coil can remain loaded in the Linetamer.

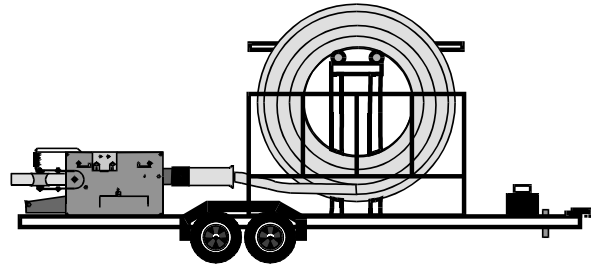

CD00370-3-31-97

If the LineTamer is on a different trailer than the coil trailer, remove the pipe from the LineTamer before transporting.

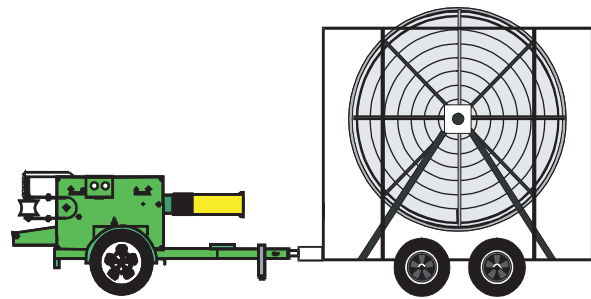

CD00311-3-31-97

TX01304-3-31-97

Lock Machine

Disconnect coil pipe from preparation machine.

Install the yellow-colored transport locking pin to prohibit movement of pipe guide.

Move seat to position inside trailer and lock into place.



PH00486-9-5-95

TX00597-8-10-95



Read Before Towing Trailer

Never tow a trailer before you check to be sure of the following.

- Brake fluid is at the proper level.
- Coupler and hitch are the right size.
- Coupler and safety chains are safely secured to hitch.
- Trailer jack is in the raised position.
- Check all fasteners for proper tightness.
- Wheel lug nuts are properly tightened.
- Wheel bearings are properly adjusted and maintained.
- Load is within maximum load carrying capacity.
- Tires are properly inflated.
- All trailer lighting is working properly.

Follow all federal, state local and industry standards when towing a trailer.

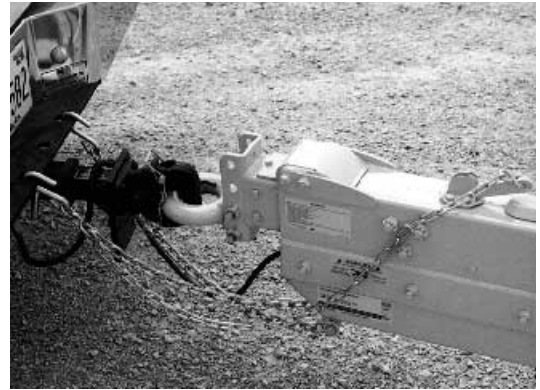

PH00808B6-17-96

TX00918-4-24-96



Preparation for Pulling



Connect Trailer

Connect trailer securely with the hitch and hook up safety chains.

CAUTION Always use safety chains with proper hookup to trailer or vehicle.

With trailer secured to vehicle, raise jack up and secure.

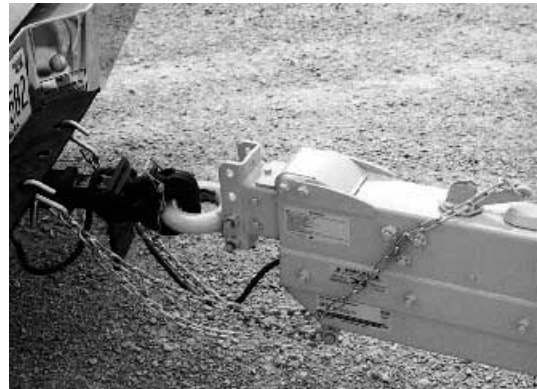

PH00808B-6-17-96

TX01305-3-31-97

Load Coil

Load coil on reel, in a cage, on a truck, trailer, or stationary reel stand. Follow trailer manufacturer's instructions for loading and unloading coils.

WARNING Coiled pipe can uncoil with considerable force, causing extreme bodily injury if not properly contained. Do not cut the steel straps around the coil until the coil is contained in a suitable reel trailer or coil cage.

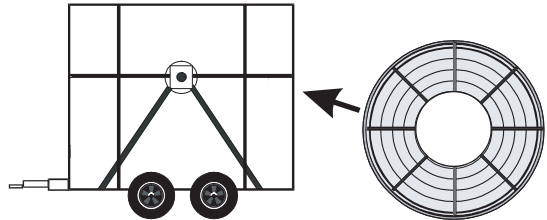

CD000371-12-15-00

TX01910-12-15-00

Securing Pipe When Using a Reel

If the pipe coil is mounted on a reel, securing the inside loose end of the pipe with a rope will prevent the pipe from twisting before it can enter the pipe preparation machine.

Using a rope with a lower tensile strength than the pipe, secure the inside loose end of pipe to the reel (this will allow the rope to burst when the end of the coil is reached).

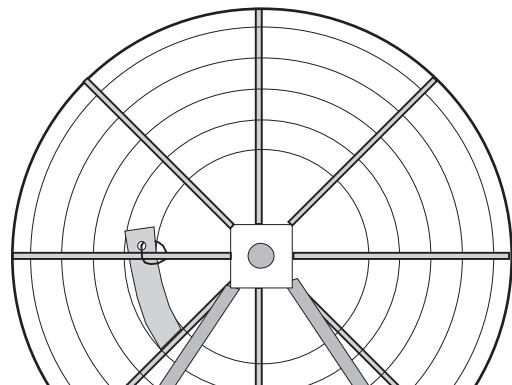

CD001648-3-1-95

TX00619-8-31-95

Unlocking Machine

Remove the yellow-colored transport locking pin for free movement of roller system guide tube and rerounder system.

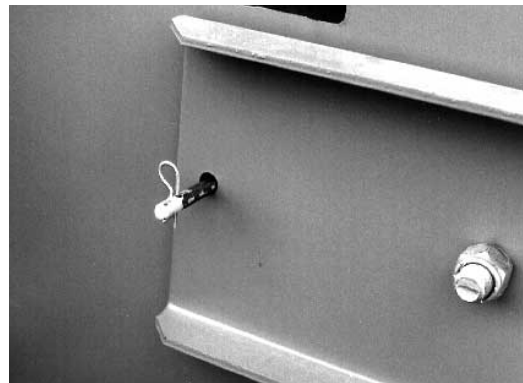

PH00486-8-21-95

TX00584-8-10-95



Preparation for Pulling



Positioning Pipe Payout

Make sure that the pipe payout from the reel or cage is lined up with the center of the pipe guide. The pipe preparation machine must be positioned directly in front of the payout from the coil.

IMPORTANT: The pipe may not be straightened or rerounded properly if the unit is not positioned correctly.

The pipe coil, LineTamer™ and pulling vehicle must be in alignment and make a straight pull during operation.



PH00493-8-28-95

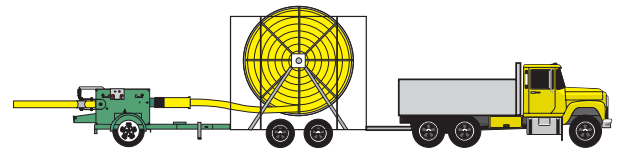

CD001799-9-1995

TX00583-8-10-95

Rerounder Rollers

When changing rerounding rollers, the stop plates must be installed as shown. Ensure that the correct rollers and guide blocks are installed for pipe size being used.

- A. 4" to 6" pipe configuration.
- B. 4" to 3" configuration.

4" to 6" Roller

A

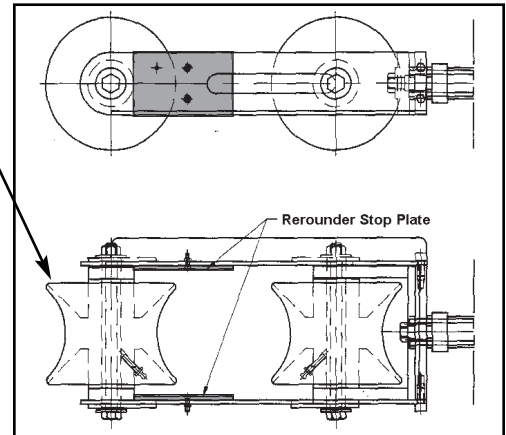

CD001749-13-95

4" to 3" Roller

B

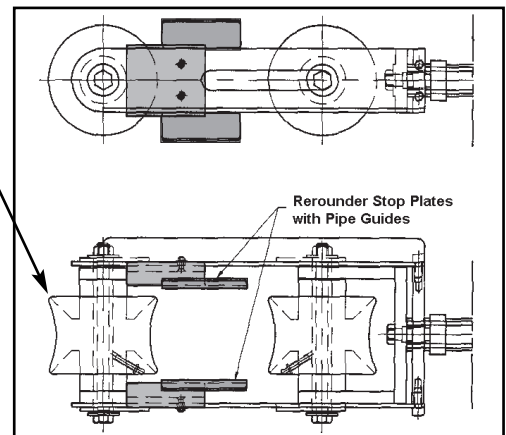

CD001739-9-13-95

TX00581-8-10-95



Preparation for Pulling



Straightening Roller

Confirm that the correct straightening roller position is set for pipe size to be used.

A. Wide roller setting for 4", 5" and 6" pipe.

B. Narrow roller setting for 3" pipe

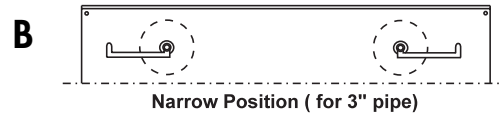
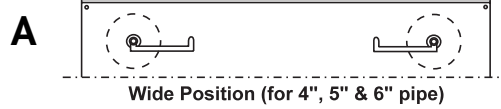

TX00580-8-10-95

CD00156-8-21-95

Check Hydraulic Fluid

Periodically check the hydraulic fluid level in reservoir. All hydraulic cylinders must be retracted before checking fluid to get an accurate level. Maintain fluid at HIGH Level.

Never allow dirt or foreign matter to enter the open tank.

Refer to the "Hydraulic Fluids" section of this manual for hydraulic oil recommendations.

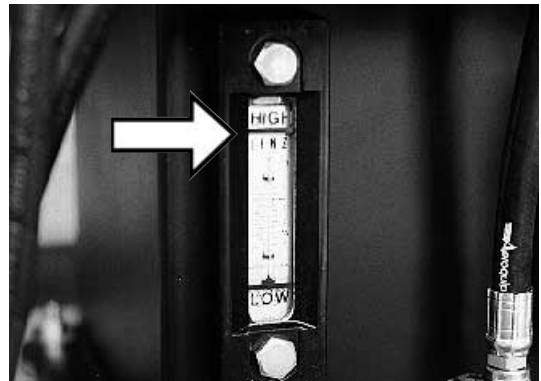

TX00966-5-22-96

PH00825-5-2-96



Operation



Read and Understand

Do not operate this equipment until you have carefully read, and understand the "Safety" and "Operation" sections of this manual, and all other equipment manuals that will be used with it.

Your safety and the safety of others depends upon care and judgment in the operation of this equipment.

Follow all applicable federal, state, local, and industry specific regulations.

McElroy Manufacturing, Inc. cannot anticipate every possible circumstance that might involve a potential hazard. The warnings in this manual and on the machine are therefore not all inclusive. You must satisfy yourself that a procedure, tool, work method, or operating technique is safe for you and others. You should also ensure that the machine will not be damaged or made unsafe by the method of operation or maintenance you choose.

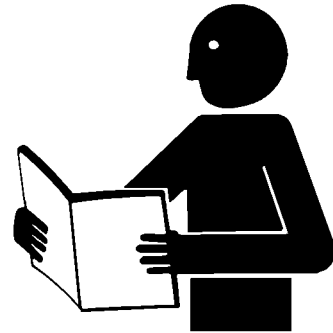

WR0052-12-1-92

TX00031-12-8-92

Pulling Force Limitations

When determining the amount of pulling force required through the LineTamer™, consideration must be given to the amount of drag on the pipe. The amount of drag can be negligible or more than the safe pulling strength of the pipe, depending on the terrain and conditions at the job site.

Nominal pulling force through LineTamer.

3" pipe = 1,250 lbs

4" pipe = 1,800 lbs

5" pipe = 2,000 lbs

6" pipe = 2,400 lbs

Total Force = Nominal + Friction

NOTICE: Total pulling force should never exceed the pipe manufacturer's safe pulling strength. Exceeding these pulling forces can damage both pipe and equipment.

It may be necessary to include a force monitoring device or a fusible link to ensure safe pulling forces are maintained.



PH004949-1-95

TX00587-8-10-95



Operation



Before Starting Operation

Always ensure that the pipe and preparation machine are properly lined up in the pulling direction and that the feed height is equal to, or higher than the pipe guide.

Always ensure that roller stops are installed before pulling. Check that roller size is correct for pipe being used.



STOP-12-22-92

TX00588-8-10-95

Start Engine

Turn the fuel valve to the ON position. Move the control lever to the CHOKE position. Pull the starter rope lightly until resistance is felt, then pull briskly.

NOTICE: Do not allow the starter grip to snap back against the engine. Return it gently to prevent damage to the starter.

When the engine warms up, move the control lever from the CHOKE position to the operating position.



PH00843-5-17-95

TX00963-5-17-96

Cutting Steel Bands



WARNING Coiled pipe can uncoil with considerable force, causing extreme bodily injury if not properly contained. Do not cut the steel bands around the coil until the coil is contained in a suitable reel trailer or coil cage.

Do not cut plastic bands at this time.



PH00498-9-1-95

TX00590-8-10-95

Cutting Plastic Bands

It may be necessary to cut the plastic bands on the coil during the pulling operation. These bands can slide together and "bunch up", posing a possible area for the pipe to kink. Use a long handled blunt nose cutter to avoid putting arms and hands inside the coil trailer/cage.

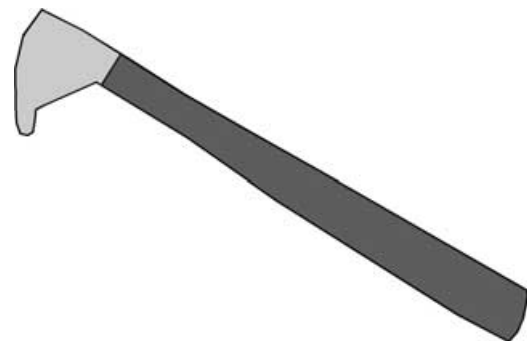

PH01129-3-31-97

TX00620-9-1-95



Pipe Threading Roller Valve

The pipe threading rollers equipped on some trailers can be used to help guide the starting end of the pipe into the LineTamer.

Use the rollers to pull the pipe down in alignment with the pipe guide on the LineTamer.

After the pipe is started, move the rollers up to help guide the coil.

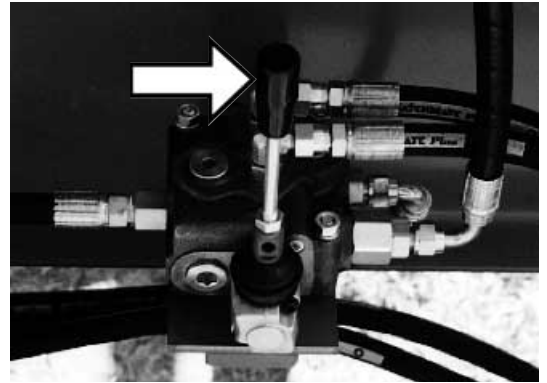

PH00844-5-17-96



PH00842-5-17-96

TX00987-6-16-96

Loading Pipe in LineTamer™

Fuse or install pulling head at pipe payout.

To load the pipe through the unit, use only soft straps or rope to avoid any sharp edges which can damage rollers.

Before engaging any rollers, ensure that pipe is through machine with at least one foot of material past rerounding rollers.



PH00497-9-1-95

TX00585-8-10-95



Operation



Pressure Settings

Charts show pressure settings for various pipe sizes and densities at different operating temperatures.

Always adjust pressure settings for both rerounder and straightener systems for changes in temperature. (Higher temperature = lower setting.)

The LineTamer™ does not have enough power to properly straighten and reround pipe at lower temperatures. Operation below 32° F is not recommended.

IMPORTANT: Charts on machine are range guidelines only for SDR 11 pipe, at speeds of 50 to 150 ft/min (less than 2 miles per hour).

- Lower speeds will require lower pressure settings.
- Thinner wall pipe will require lower pressure settings.
- Do not exceed 150 ft/min. pulling speed.

TX00592-8-10-95

Rerounder Pressure Chart				
Gauge Pressure (PSI)				
Ambient Temperature (°F)				
	PE3408		PE3408	
Pipe Size	32°-70°	71°-110°	32°-70°	71°-110°
3"	300	250	250	200
4"	600	500	500	450
5"	900	850	850	800
6"	1250	1200	1200	1150

Straightener Pressure Chart				
Gauge Pressure (PSI)				
Ambient Temperature (°F)				
	PE3408		PE2406	
Pipe Size	32°-70°	71°-110°	32°-70°	71°-110°
3"	250	250	250	200
4"	500	450	450	400
5"	750	700	700	650
6"	1550	1500	1500	1400

CD00635-12-15-00

CD00636-12-15-00

Rerounder Pressure

Select rerounder pressure control valve and set appropriate pressure value, based on pipe size and material. Refer to rerounder pressure chart.

NOTICE: Pressure gauge will indicate a lower pressure than your initial setting if pull is stopped, but will return to original setting when the pull begins again. If you adjust the setting while the pull is stopped, the setting will be higher than necessary when the pull starts again.

Rerounder pressure setting can be maintained during short stops, but should be reduced during stops of 10 minutes or more.

TX00988-6-18-96

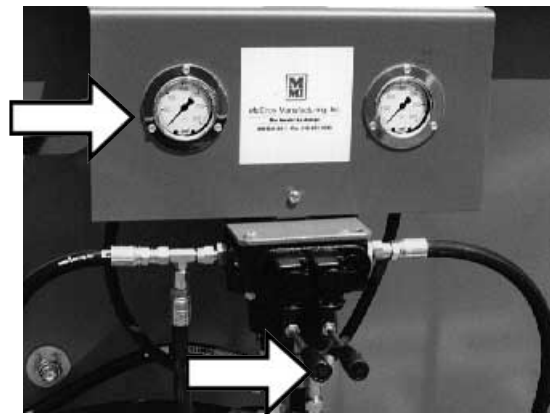

JPH00850B-6-18-96

Straightener Pressure

Select straightener pressure control valve and start pulling pipe slowly while applying pressure to straightener system. Set appropriate pressure value, based on pipe size and material. Refer to straightener pressure chart.

IMPORTANT: Always reduce the pressure on the straightener system whenever the pipe pull is discontinued. If the pipe pull stops, the straightener system can kink the pipe when under pressure.

Re-engage when pull is continued, to the initial pressure setting on straightener gauge.

TX00989-6-18-96

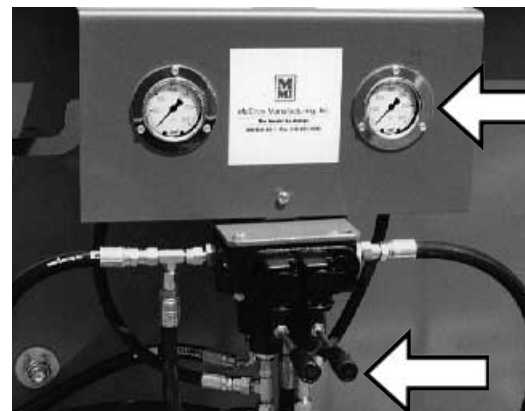

JPH00850C-8-96



Operation



Monitor Pressure

Due to variations in temperature and pulling speed, adjustments may have to be made to pressure settings for the straightener and rerounder systems to obtain the best results.

IMPORTANT: Final ovality measurements are only reliable after two hours, due to slow relaxation of pipe.



TX00594-8-10-95

PH00855-6-16-96

Precautions

Do not operate this equipment until you have carefully read, and understand the "Safety" and "Operation" sections of this manual, and all other equipment manuals that will be used with it.

Do not stand in front or behind preparation machine during pulling process.

Always operate machine from control-side of unit.

Operator should always be in radio contact with driver of pulling vehicle.

Never stand on preparation machine during operation.

Keep hands and legs away from machine during operation.

Do not sit or step on pipe during pull.

All non-participating personnel should be at least 15 feet away from pipe coil and machine during pull.



TX00586-8-10-95

SAFE1ST12-22-95

End of Coil with Pipe Secured

If the pipe coil was mounted on a reel and the inside end tied off, continue the pull until the pipe has reached the end of the coil.

Do not stop the pull when the rope securing the end of the pipe is reached. Let the pulling load break the rope. This keeps the pipe from twisting until the last few feet get to the pipe preparation machine.

If the pipe twists, it may not be straightened or rerounded properly.

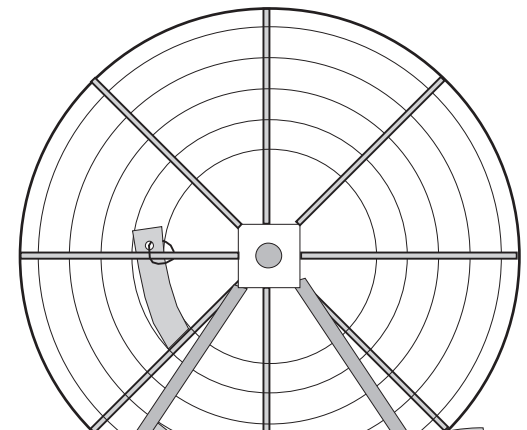

TX00621-9-5-95

CD001648-31-95



Maintenance



Preventative Maintenance

To insure optimum performance, the machine must be kept clean and well maintained.

With reasonable care, this machine will give years of service. Therefore, it is important that a regular schedule of preventive maintenance be kept.

Store machine inside, out of the weather, whenever possible.

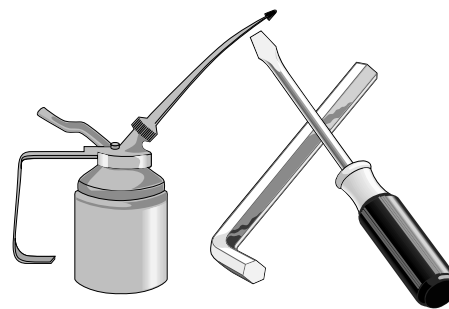

CD00142-11-2-94

TX00428-8-10-95

Washing the Machine

An important factor in the service life of this machine is cleanliness. The machine should be cleaned with soap and water as needed.

When exposed to dust and mud in a field location, the machine should be washed at the end of each days work.



CD00178-9-15-95

TX00601-8-10-95

Check Hydraulic Fluid

Periodically check the hydraulic fluid level in reservoir. All hydraulic cylinders must be retracted before checking fluid to get an accurate level. Maintain fluid at HIGH Level.

Never allow dirt or foreign matter to enter the open tank.

Refer to the "Hydraulic Fluids" section of this manual for hydraulic oil recommendations.

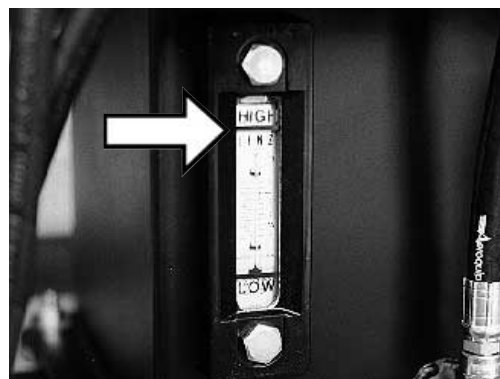

PH00825-6-16-96

TX00966-5-22-96

Grease Bearings and Sleeves

Periodically grease all fittings for bearings and sleeves.

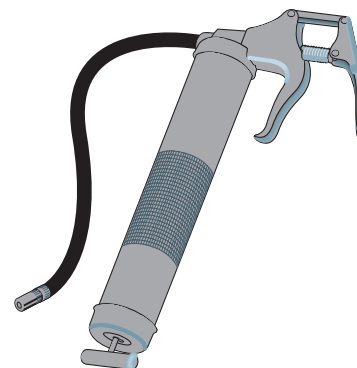

CD00183-11-6-95

TX00990-6-18-96

Grease Moving Parts

All moving parts should be greased periodically. All pipe rollers have fittings for lubricating the bearings. Grease the fittings once a month, or as required.

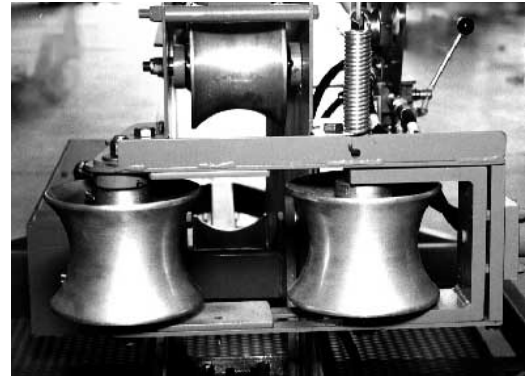

PH00502-9-5-95

Grease sliding linkage of rerounder system.

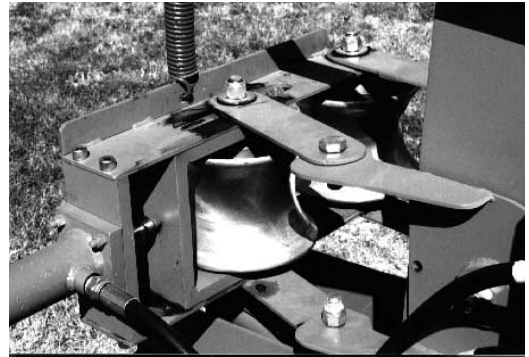

PH00503-9-5-95

TX01306-3-31-97



Hydraulic Fluids



Hydraulic Fluids

The use of proper hydraulic oil is mandatory to achieve maximum performance and machine life. Hydraulic oil should have anti-wear and other special additives. The oil must meet 150 SSU at 100° F, with the exception of a cold weather operation.

The following table specifies the oil temperature at various viscosities. The temperature rise of the hydraulic oil can vary from 30° F to about 70° F over the ambient temperature depending on the pressure setting, age of the pump, wind, etc.

Mobil DTE 15M multi-grade hydraulic oil is installed at our factory. The advantage of this oil is a wider temperature range, however, this oil should not be used for continuous operation below 20° F

For use in extremely cold ambient temperatures, we suggest Mobile DTE 11, which can be used to -16° F. This oil should not be used for continuous operation above 100° F (oil temperature).

TX00444-10-20-95

Hydraulic Fluids Characteristics																
Manufacturer	Fluid Name	SSU 100F	SSU 210F	V.I.	-20F	-10F	0F	10F	30F	50F	70F	90F	110F	130F	150F	Range °F
Chevron	Chevron 32AW	173	45	100					*****	*****	*****	*****	*****			15-125
	Chevron 46AW	238	49	98					*****	*****	*****	*****	*****			25-142
	Chevron 68AW	335	54	99					*****	*****	*****	*****	*****			34-155
Phillips	Magnus A32	170	45	101					*****	*****	*****	*****	*****			15-123
	Magnus A46	225	48	98					*****	*****	*****	*****	*****			24-136
	Magnus A68	350	54	98					*****	*****	*****	*****	*****			37-151
Shell	TellusT32	150	44	102			*****	*****	*****	*****	*****	*****	*****			-2-124
	TellusT46	215	48	103					*****	*****	*****	*****	*****			7-135
	TellusT68	315	53	89					*****	*****	*****	*****	*****			20-152
Sun	Sunvis 2105	206	52	167				*****	*****	*****	*****	*****	*****			5-140
	Sunvis 832	164	44	99					*****	*****	*****	*****	*****			12-121
	Sunvis 846	236	49	98					*****	*****	*****	*****	*****			23-136
	Sunvis 868	352	55	98					*****	*****	*****	*****	*****			34-152
Unical	Unax AW 32	150	44	107					*****	*****	*****	*****	*****			12-125
	Unax AW 46	215	48	107					*****	*****	*****	*****	*****			20-137
	Unax AW 68	315	54	107					*****	*****	*****	*****	*****			30-152
Mobil	DTE 11M	87	40	145	*****	*****	*****	*****	*****	*****	*****	*****	*****			-27-87
	DTE 13M	165	48	140			*****	*****	*****	*****	*****	*****	*****			5-130
	DTE 24	162	44	95					*****	*****	*****	*****	*****			23-120
	DTE 25	227	47	95					*****	*****	*****	*****	*****			37-137
	DTE 26	335	53	95					*****	*****	*****	*****	*****			47-150
Exxon	Univis N-32	177	49	164			*****	*****	*****	*****	*****	*****	*****			5-140
	Univis N-46	233	55	163					*****	*****	*****	*****	*****			25-142
	Univis N-68	376	68	160					*****	*****	*****	*****	*****			34-155

NOTE: This chart is based on the pump manufacturer recommendations of 100 to 4000 SSU limits.

NOTE: Temperatures shown are fluid temperatures. - NOT ambient temperatures.



Specifications



LineTamer™

Dimensions: 50" H x 46" W x 96" L (LineTamer™ only)

Weight: 730 lbs.

Pipe Capacity: 3", 4", 5" & 6" IPS pipe
4", 5" & 6" Pipe Rollers Standard
(3" & 4" Pipe Rollers Optional)

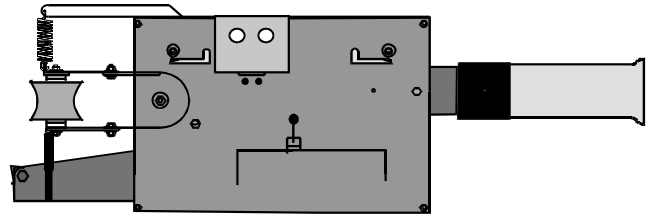

CD00302-3-1-97

Hydraulic Power Unit

Fluid: Mobil DTE 15M or equivalent

Reservoir Capacity: 5 gallons

Maximum Pressure: 2500 psi

Flow: 2.0 GPM @ 2000 psi

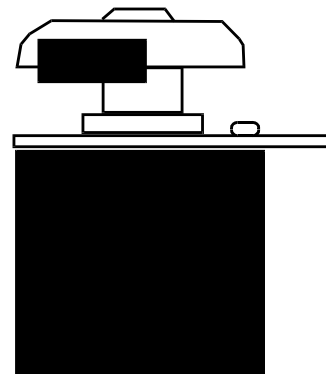

CD00304-5-20-96



McElroy Manufacturing, Inc.

The leader by design

P.O.Box 580550 • Tulsa, Oklahoma 74158-0550
(918) 836-8611 • Fax: (918) 831-9285
www.mcelroymfg.com