



PUBLIC UTILITY TRANSPORTATION SYSTEMS

LTSLSPU0116 11/03

A53-6477

TRANSFORMER/CARGO TRAILER



GENERAL

GVWR: 9,500 lbs
 GAWR: 5,000 lbs. (2)
 Empty Weight: 2,360 lbs
 Overall Dimensions: 173" x 83" x 42-25/32" (L x W x H)
 Bed Dimensions: 108" x 59" x 20" (L x W x H)
 Tongue Jack: 7000# sidewind w/dolly wheel
 Hitch: 3" Eye
 Safety Chains: (2) 3/8" steel chain with safety hook

RUNNING GEAR

Axle: (2) 5,000 lbs Dexter Torflex
 Brakes: Electric 12" x 2" (all wheels)
 Tires: Size: ST225/75R15LRD Type: Radial
 Wheels: 15" x 6" Conventional Steel with 6 bolts on 5.5" circle

FRAME STRUCTURAL

Frame Rails:	Material:	C8 x 11.5 Structural Channel	Grade: ASTM A36
Fenders:	Material:	12ga Galvanneal	Grade: ASTM A525
Fender Steps:	Material:	12ga Galvanneal	Grade: ASTM A525

CARGO AREA

Sides:	Material:	12 ga. Galvanneal	Grade: ASTM A525
Deck:	Material:	12 ga. Galvanneal	Grade: ASTM A525
Gate:	Front and Rear, travel s 90 deg. (chain limited) or 180 deg.		
Gate Hinge:	Bolt-on stainless steel hinge brackets w/ stainless steel hinge rod		

FINISH

Hot Dipped Galvanizing

ELECTRICAL

Lights & Reflectors:	To Federal D.O.T. Requirements
Wire Harness:	No internal splices, enclosed in protective loom
Electrical Connection:	7-pin receptacle

OPTIONS

Rear stabilizer jacks
 8 - 10,000# Lashing rings in deck

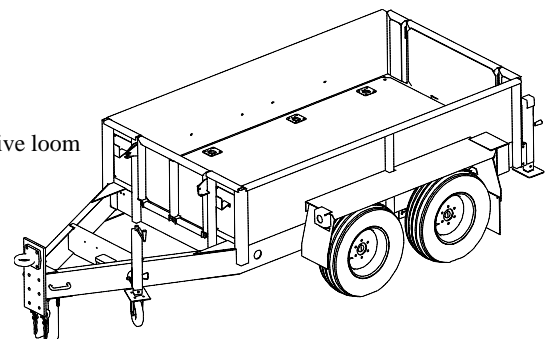

MGS Incorporated

178 Muddy Creek Church Rd. Denver, PA 17517

Phone: 800-952-4228 Fax: 717-336-4071

Email: cmcquate@mgsmail.com