

# Operator's Manual

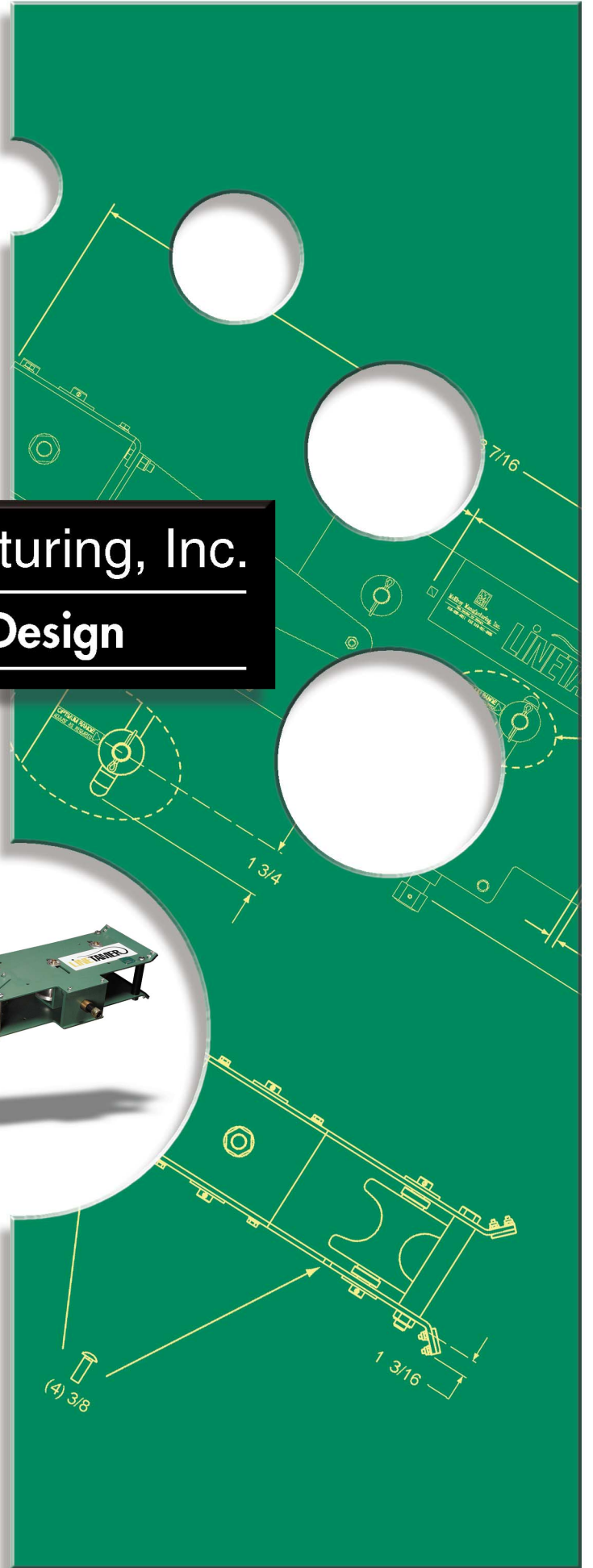

McElroy Manufacturing, Inc.  
The Leader by Design

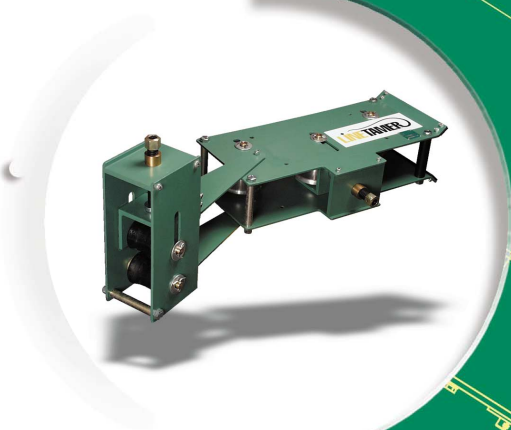

2" IPS Pipe Preparation Machine



Patent No. 5,676,009



# Introduction



## Thank you for purchasing this McElroy product.

The McElroy LineTamer™ is designed to remove coil set and reround coiled pipe for easier fusion and to minimize the possibility of dangerous uncontrolled pipe recoil. The LineTamer consists of a straightening unit and a rerounding unit which prepares 2" IPS high and medium density coiled polyethylene pipe for installation. With reasonable care and maintenance, this machine will give years of satisfactory service.

Before operating this machine, please read this manual thoroughly, and keep a copy with the machine for future reference. This manual is to be considered part of your machine.

TX01600-10-9-98



PH01477-11-3-98

## World Class Training

This manual is intended as a guide only and does not take the place of proper training by qualified instructors. The information in this manual is not all inclusive and can not encompass all possible situations that can be encountered during various operations.

McElroy Manufacturing, Inc., offers advanced training classes to enhance efficiency, productivity, safety and quality. Training is available at our facility or on-site at your location. Call (918) 836-8611

TX01083-12-10-96



PH00917-5-16-98



# Warranty



## LIMITED WARRANTY

McElroy Manufacturing, Inc. guarantees this product to the original purchaser against workmanship and material defects for one (1) year from date of shipment, with the exception of purchased items (such as electronic devices, pumps, switches, tires, engines, etc.), in which case that manufacturer's warranty applies. This warranty does not apply to any product or component which has been repaired or altered by anyone other than McElroy Manufacturing, Inc., or has become damaged due to misuse, negligence or casualty, or has not been operated or maintained according to McElroy Manufacturing, Inc.'s printed instructions and warnings.

Materials returned to McElroy Manufacturing, Inc. for warranty work, repair, etc., **must have a Return Material Authorization (RMA) number**, and be so noted on the package at time of shipment. This number may be obtained by calling (918) 836-8611.

If seller's review indicates that warranty applies, the defective product will be repaired or replaced and returned to purchaser F.O.B. Tulsa, Oklahoma.

McElroy Manufacturing, Inc. is not responsible or liable for loss of any sort including incidental and consequential damages.

McElroy Manufacturing, Inc. specifically disavows any other representations as to warranty or liability, related to the condition or use of the product.

For assistance, inquiries shall be directed to McElroy Manufacturing, Inc., P.O. Box 580550, 833 North Fulton, Tulsa, Oklahoma 74158-0550, (918) 836-8611, Telex No. 200470, Fax No. (918) 831-9285

**(Copy information listed on the Warranty Card for your records)**

LineTamer™

Serial No. \_\_\_\_\_

Model No. \_\_\_\_\_

## DISCLAIMER OF LIABILITY

McElroy Manufacturing, Inc. accepts no responsibility of liability for fusion joints. Operation and maintenance of the product is the responsibility of others. We recommend qualified joining procedures be followed when using McElroy fusion equipment.

McELROY MAKES NO OTHER WARRANTY OF ANY KIND WHATEVER, EXPRESS OR IMPLIED; AND ALL IMPLIED WARRANTIES OF MERCHANTABILITY AND FITNESS FOR A PARTICULAR PURPOSE WHICH EXCEED THE AFORESTATED OBLIGATION ARE HEREBY DISCLAIMED BY McELROY.

## PRODUCT IMPROVEMENT

McElroy Manufacturing, Inc. reserves the right to make any changes in or improvements on its products without incurring any liability or obligation to update or change previously sold machines and/or the accessories thereto.

## TERMS AND CONDITIONS

LineTamers are net 30 days - Subject to credit approval. A carrying charge of 1-1/2% per month computed from invoice date will apply to invoices not paid within 30 days.

McElroy Manufacturing, Inc. must be notified of any discrepancy in shipment, order, and/or invoice within 10 days after receipt.

Freight is F.O.B. Tulsa, Oklahoma - usually motor freight collect or UPS unless otherwise specified.

Prices are subject to change without notice.

Minimum order is \$50.00.

TX01302-3-27-97



# Table of Contents



## Equipment Safety

Safety Alerts . . . . .	1-1
Read and Understand . . . . .	1-1
General Safety . . . . .	1-2
Wear Safety Equipment . . . . .	1-2
Cutting Coil Bands . . . . .	1-2
Keep Personnel Away . . . . .	1-3
Coiled Pipe Safety . . . . .	1-3

## Overview

Usage Options . . . . .	2-1
Mounting LineTamer . . . . .	2-3
Nomenclature . . . . .	2-4

## Transporting

Secure Pipe Before Transporting . . . . .	3-1
Read Before Towing Trailer . . . . .	3-1

## Operation

Read and Understand . . . . .	4-1
Pulling Force Limitations . . . . .	4-1
Load Coil . . . . .	4-2
Cutting Bands . . . . .	4-2
Cutting Plastic Bands . . . . .	4-2
Open Space Between Rollers . . . . .	4-3
Loading Pipe in LineTamer . . . . .	4-3
Readjusting Rollers . . . . .	4-3
Setting Rerounding Rollers . . . . .	4-3
Setting Straightening Rollers . . . . .	4-4
Precautions . . . . .	4-4
Pulling Pipe . . . . .	4-4

## Maintenance

Preventive Maintenance . . . . .	5-1
Washing the Machine . . . . .	5-1
Roller Adjustment Shafts . . . . .	5-1

## Specifications

Specifications . . . . .	6-1
--------------------------	-----

COPYRIGHT © 1999  
 McELROY MANUFACTURING, INC.  
 Tulsa, Oklahoma, USA  
 All rights reserved

All product names or trademarks are property of their respective owners. All information, illustrations and specifications in this manual are based on the latest information available at the time of publication. The right is reserved to make changes at any time without notice.



## Safety Alerts



This hazard alert sign appears in this manual. When you see this sign, carefully read what it says. **YOUR SAFETY IS AT STAKE.**

You will see the hazard alert sign with these words: **DANGER**, **WARNING**, and **CAUTION**.



Indicates an imminently hazardous situation which, if not avoided, will result in death or serious injury.



Indicates a potentially hazardous situation which, if not avoided, could result in death or serious injury.



Indicates a hazardous situation which, if not avoided, may result in minor or moderate injury.

In this manual you should look for two other words: **NOTICE** and **IMPORTANT**.

**NOTICE:** can keep you from doing something that might damage the machine or someone's property. It may also be used to alert against unsafe practices.

**IMPORTANT:** can help you do a better job or make your job easier in some way.

TX00030-12-1-92



WR00051-11-30-92

## Read and Understand

Do not operate this equipment until you have carefully read, and understand the "Safety" and "Operation" sections of this manual, and all other equipment manuals that will be used with it.

Your safety and the safety of others depends upon care and judgment in the operation of this equipment.

Follow all applicable federal, state, local, and industry specific regulations.

McElroy Manufacturing, Inc. cannot anticipate every possible circumstance that might involve a potential hazard. The warnings in this manual and on the machine are therefore not all inclusive. You must satisfy yourself that a procedure, tool, work method, or operating technique is safe for you and others. You should also ensure that the machine will not be damaged or made unsafe by the method of operation or maintenance you choose.



TX00031-12-8-92

WR00052-12-1-92



# Equipment Safety



## General Safety

Safety is important. Report anything unusual that you notice during set up or operation.

**LISTEN** for thumps, bumps, rattles, squeals, air leaks, or unusual sounds.

**SMELL** odors like burning insulation, hot metal, burning rubber, hot oil, or natural gas.

**FEEL** any changes in the way the equipment operates.

**SEE** problems with wiring and cables, hydraulic connections, or other equipment.

**REPORT** anything you see, feel, smell, or hear that is different from what you expect, or that you think may be unsafe.



SAFE15T12-22-92

TX00114-4-22-93

## Wear Safety Equipment

Wear a hard hat, safety shoes, safety glasses, and other applicable personal protective equipment.

Remove jewelry and rings, and do not wear loose-fitting clothing or long hair that could catch on controls or moving machinery.

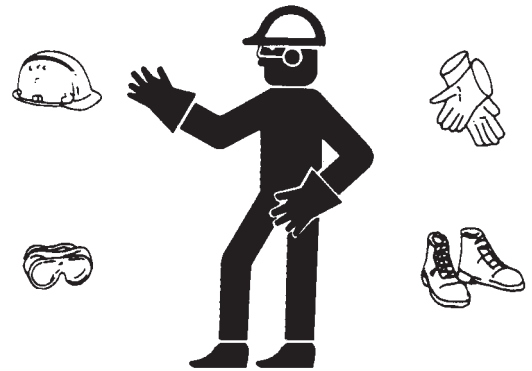

WV00053-12-2-92

TX00032-4-7-93

## Cutting Coil Bands



**WARNING** Coiled pipe can uncoil with considerable force, causing extreme bodily injury if not properly contained. Do not cut the straps around the coil until the coil is contained in a suitable reel trailer or coil cage.



CD00481-10-12-98

TX01581-1-11-99



## Keep Personnel Away

**WARNING** Moving parts in this machine can cause severe bodily harm. All personnel must keep hands and body away from moving parts of machine.

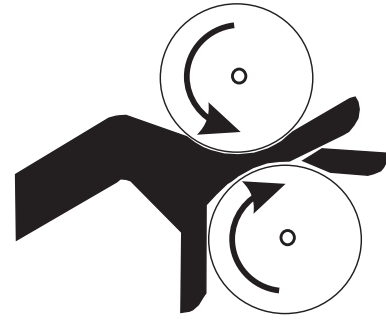

CD00155-8-9-95

TX01601-10-12-98

## Coiled Pipe Safety

When the tail end of the coil unwinds, or when the pipe is being cut, the ends can move suddenly in any direction with great force.

**WARNING** Loose ends of coiled pipe can move with great force in any direction. Keep personnel at least 15 feet away.

When pulling pipe through the LineTamer, personnel and equipment must stay at least 15 feet away from machine and pipe ends.



CD00482-10-13-98

## Cold Weather Conditions

Operation below 32° F is not recommended.

The forceful movement of loose ends of pipe become more pronounced in cold weather and all personnel must be aware for their own safety.

There are practical limits to pulling pipe in cold weather. The ability of the pipe to be straightened and rerounded diminishes.

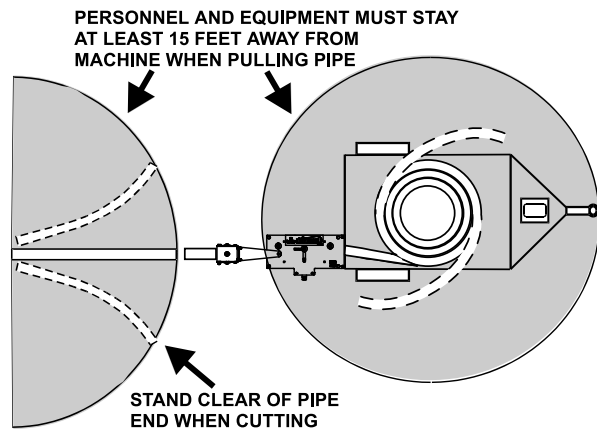

CD00483-10-13-98

TX01582-1-11-99



# Overview



## Usage Options

### I: Stringing & Straightening Pipe

Pulling pipe from LineTamer and stringing pipe on the ground for direct in-trench burial.

### II: Stringing & Planting Pipe

Pulling LineTamer behind vehicle with planting vehicle pulling pipe directly into ground.

### III: Stringing & Plowing Pipe

Plowing vehicle pulling pipe directly into ground from the LineTamer.

### IV: Straightening Pipe for Directional Boring

Directional boring machine pulling pipe through pre-drilled hole from LineTamer.

### V: Straightening Pipe for Relining

Pipe being pulled from LineTamer through existing pipe for relining.

TX01583-1-11-99

## I: Stringing & Straightening Pipe

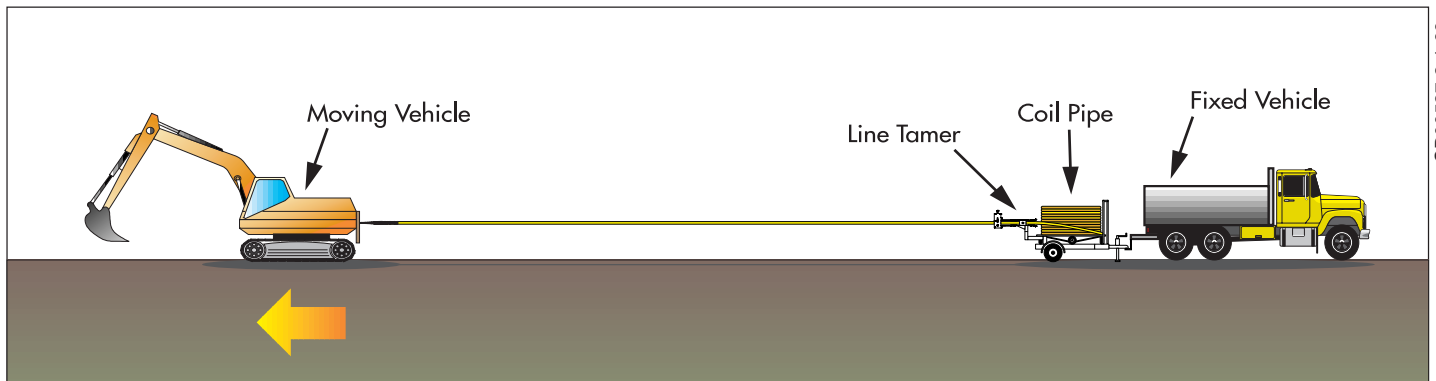

CD00527-2-1-99

## II: Stringing & Planting Pipe

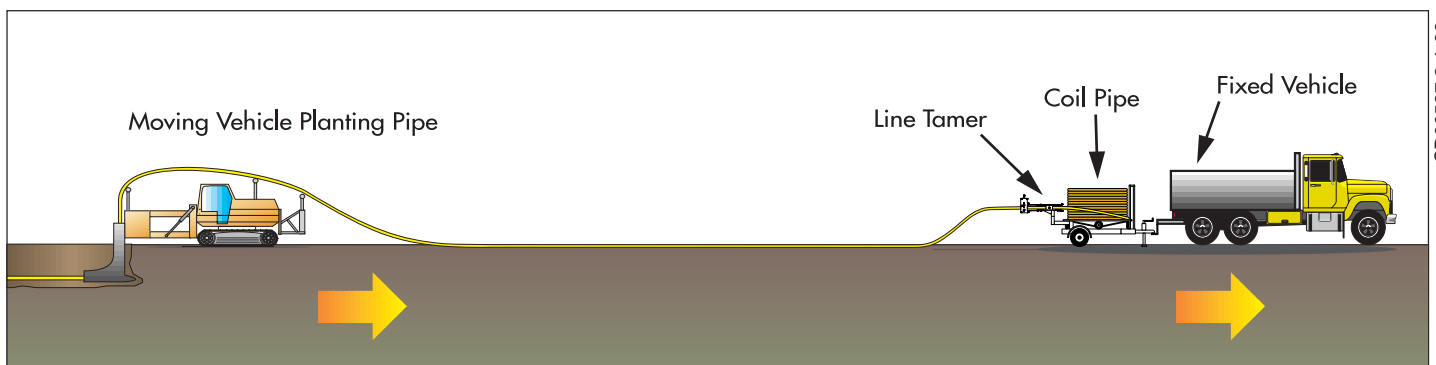

CD00527-2-1-99



# Overview



## III: Stringing & Plowing Pipe

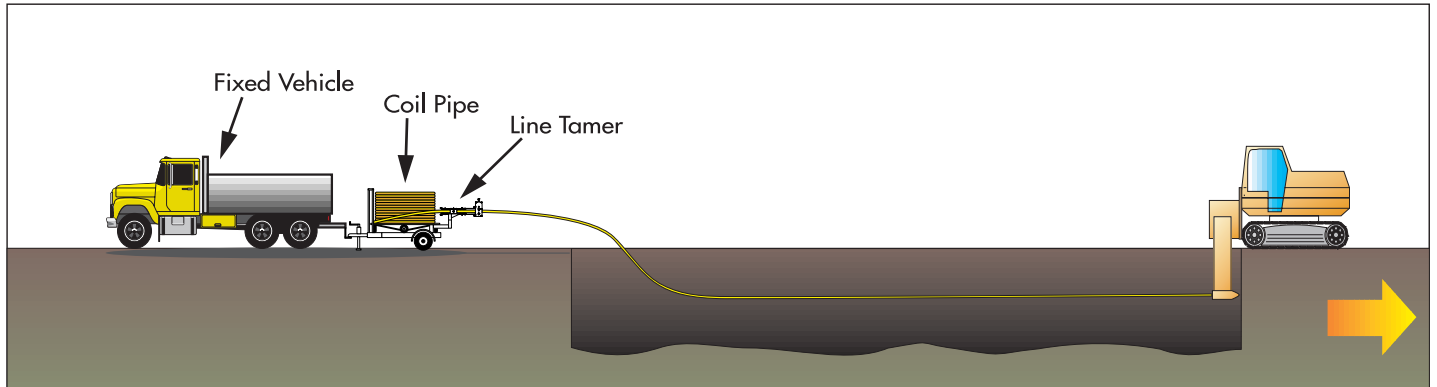

CD00527-2-1-99

## IV: Straightening Pipe for Directional Boring

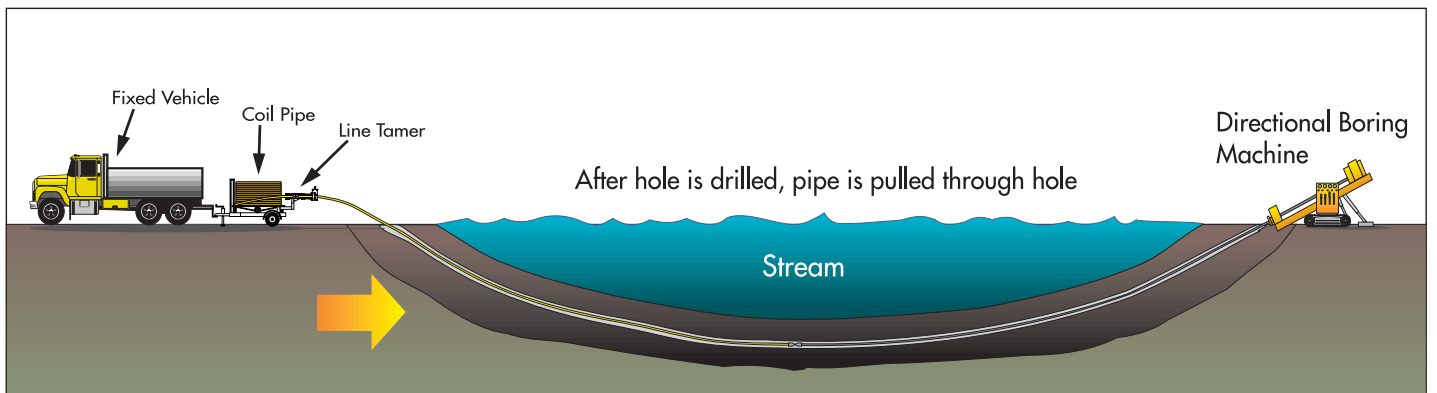

CD00527-2-1-99

## V: Straightening Pipe for Relining

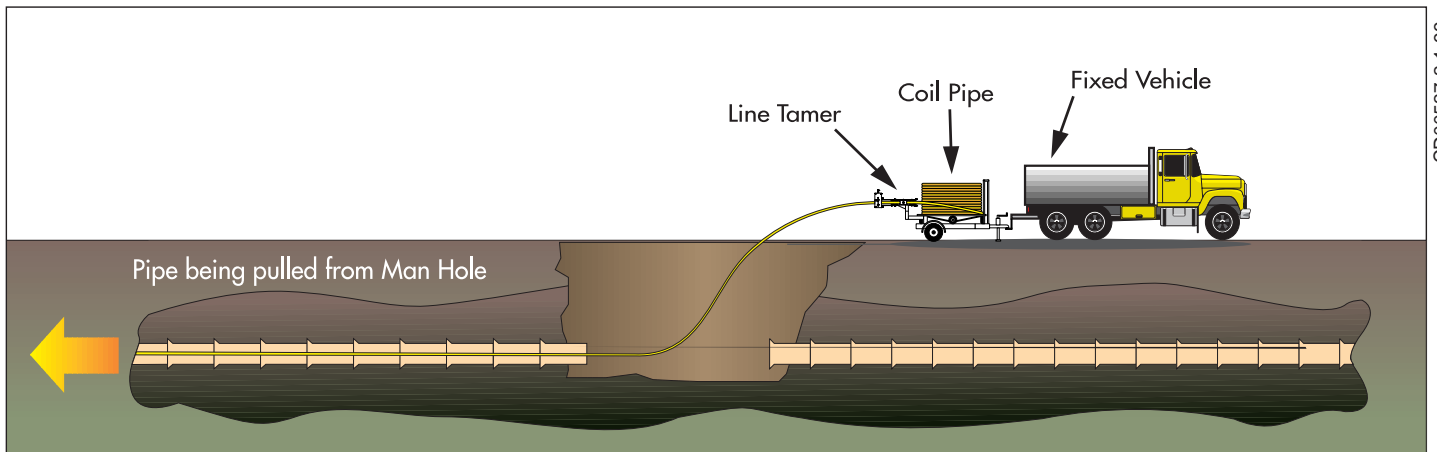

CD00527-2-1-99



## Mounting LineTamer

Safe handling of coiled pipe, conduit, or duct requires the McElroy LineTamer mounted on a specially designed, heavy duty, coil pipe trailer.

The LineTamer should be mounted ahead of the payout of the coil in a manner that won't put the pipe in a bind. It is designed for use with pipe that is uncoiling in a clockwise direction, and must be inverted for use with pipe uncoiling counterclockwise.

The mounting height should be toward the bottom half of the coil.

For best results, the LineTamer should be mounted as shown. This mounting arrangement permits the reround roller assembly to pivot freely. It also allows the LineTamer to self adjust to small changes in the pulling direction angle.

The LineTamer should be mounted on a double pivoting arm that allows both the arm to pivot freely and the LineTamer to pivot freely. The mounting style and location should also permit easy loading of the coil and safe trailering down the road.

The LineTamer has 4 mounting holes for attaching the machine to a frame. Use four 3/8" Carriage bolts to secure the machine. See the specification section for mounting dimensions.

TX01595-2-1-98

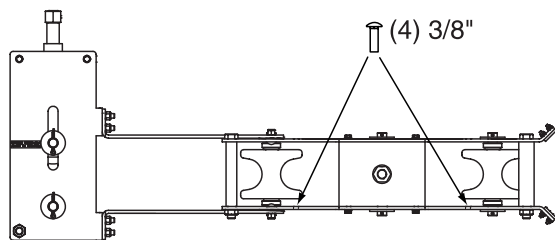

CD000490-2-1-99

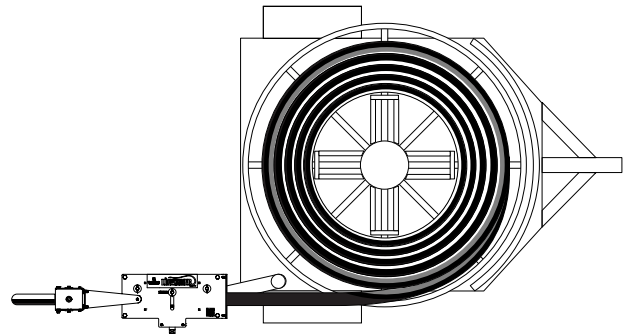

CD000524-1-12-99

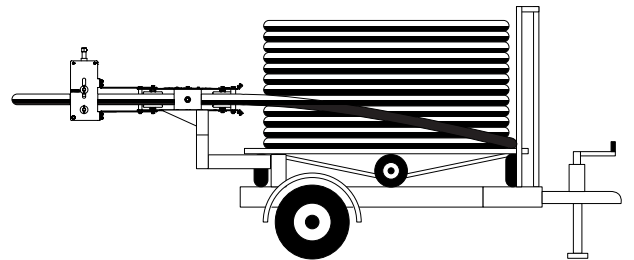

CD000524-1-12-99

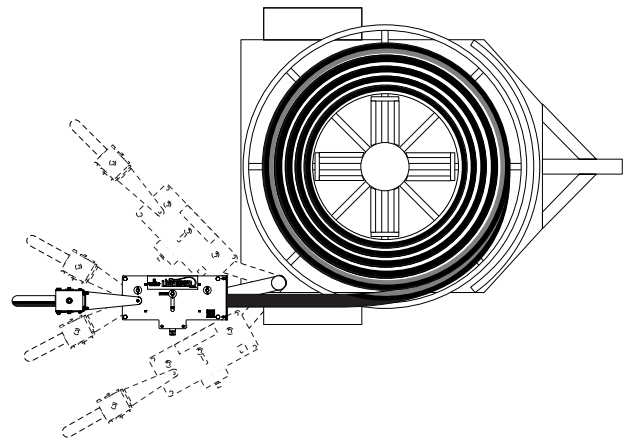

CD-000525-1-12-99

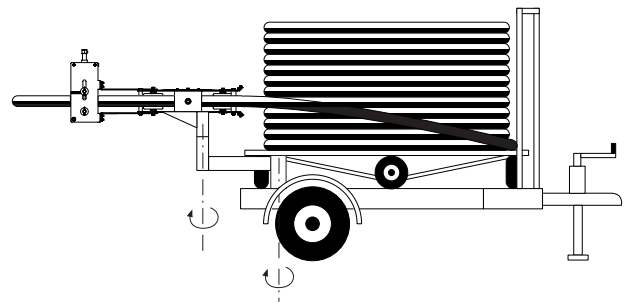

CD-000525-1-12-99

## Nomenclature

- ① Rerounding Rollers Adjustment Shaft
- ② Straightening Rollers
- ③ Pipe In
- ④ Straightening Roller Adjustment Shaft
- ⑤ Rerounding Roller Assembly
- ⑥ Pipe Out
- ⑦ Reround Rollers

TX01594-2-3-99

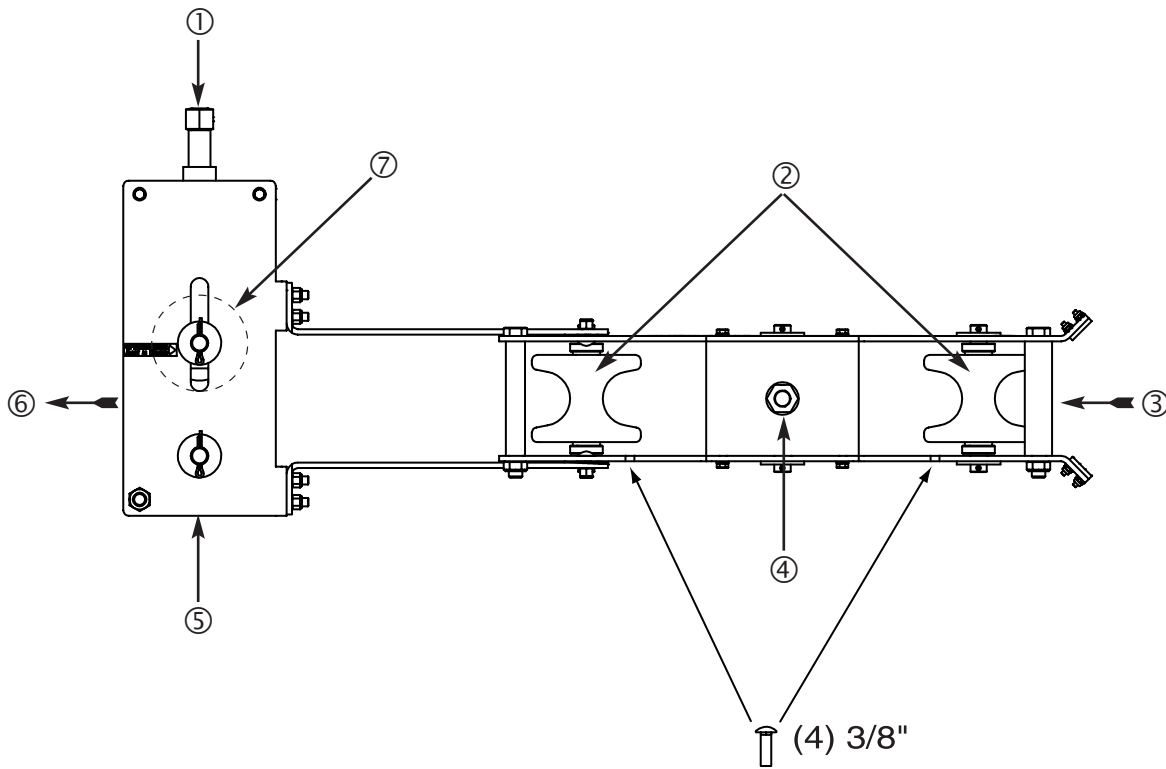

CD00526-2-1-99



## Secure Pipe Before Transporting

The coil of the pipe should be secured in the trailer before transporting. Use locking straps or similar means to secure the coil to itself as well as the trailer frame. This will prevent damage to the pipe and trailer from shifting loads at trailering speeds.

The LineTamer must also be secured to the trailer prior to towing the trailer.

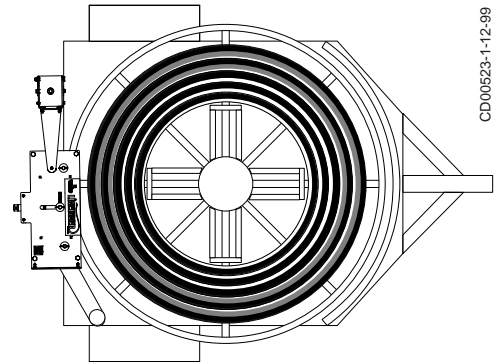
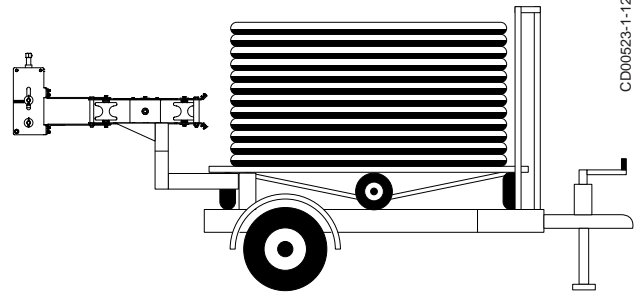

TX01593-1-12-99

## Read Before Towing Trailer

**Never tow a trailer before you check to be sure of the following:**

- Brake fluid is at the proper level.
- Coupler and hitch are the right size.
- Coupler and safety chains are safely secured to hitch.
- Trailer jack is in the raised position.
- Check all fasteners for proper tightness.
- Wheel lug nuts are properly tightened.
- Wheel bearings are properly adjusted and maintained.
- Load is within maximum load carrying capacity.
- Tires are properly inflated.
- All trailer lighting is working properly.
- Follow all federal, state local and industry standards when towing a trailer.

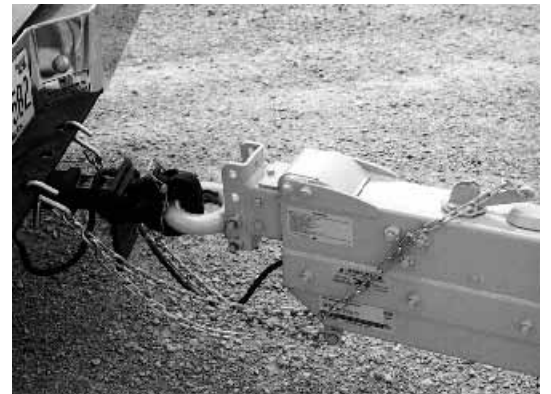

TX00918-4-24-96



## Read and Understand

Do not operate this equipment until you have carefully read, and understand the “Safety” and “Operation” sections of this manual, and all other equipment manuals that will be used with it.

Your safety and the safety of others depends upon care and judgment in the operation of this equipment.

Follow all applicable federal, state, local, and industry specific regulations.

McElroy Manufacturing, Inc. cannot anticipate every possible circumstance that might involve a potential hazard. The warnings in this manual and on the machine are therefore not all inclusive. You must satisfy yourself that a procedure, tool, work method, or operating technique is safe for you and others. You should also ensure that the machine will not be damaged or made unsafe by the method of operation or maintenance you choose.



WPR0052-12-1-92

TX00031-12-8-92

## Pulling Force Limitations

When determining the amount of pulling force required through the LineTamer, consideration must be given to the amount of drag on the pipe. The amount of drag can be negligible or more than the safe pulling strength of the pipe, depending on the terrain and conditions at the job site.

Nominal pulling force through the 2” LineTamer is 1,100 lbs.

Total Force = Nominal + Friction

**NOTICE:** Total pulling force should never exceed the pipe manufacturer’s safe pulling strength. Exceeding these pulling forces can damage both pipe and equipment.

It may be necessary to include a force monitoring device or a fusible link to ensure safe pulling forces are maintained.



PH01477-11-3-98

TX01605-10-23-98



## Load Coil

Load coil on trailer, on reel, in a cage or stationary reel stand. Follow manufacturer's instructions for loading and unloading coils.

**⚠ WARNING** Coiled pipe can uncoil with considerable force, causing extreme bodily injury if not properly contained. Do not cut the straps around the coil until the coil is loaded and properly contained.

TX01584-1-11-99



PH01478-11-3-98

## Cutting Bands

Coiled pipe can uncoil with considerable force, causing extreme bodily injury if not properly contained. Do not cut the bands around the coil until the coil is contained in a suitable reel trailer or coil cage.

Do not cut all of the plastic bands at this time. Cut only those necessary for the amount of pipe to be uncoiled

TX01586-1-11-99



PH01482-11-9-98

## Cutting Plastic Bands

It will be necessary to cut the plastic bands on the coil during the pulling operation. These bands can be of considerable strength. If not cut they could cause the pipe to kink. Use a long handled blunt nose cutter to avoid putting arms and hands inside the coil trailer/cage.

TX01587-1-11-99

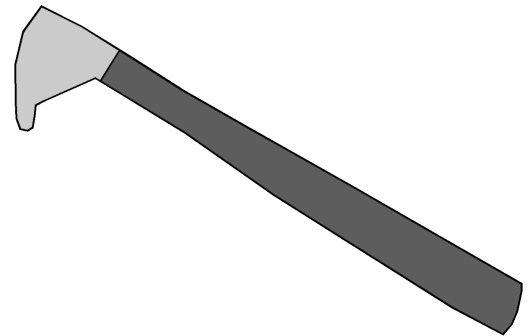

PH01129-3-31-98



## Open Space Between Rollers

- ① Turn rerounding rollers adjustment shaft counterclockwise as far as possible to open up the rollers.
- ② Turn straightening rollers adjustment shaft counterclockwise as far as possible to open up the space between the rollers.

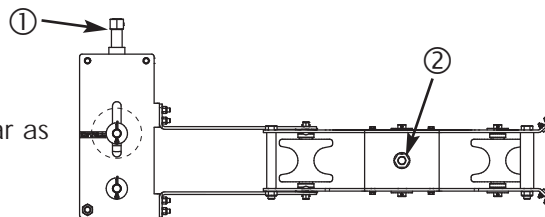

CD000495-2-1-99

TX01588-1-11-99

## Loading Pipe in LineTamer

Install pulling head or other means of pulling, at pipe payout.

To load the pipe through the LineTamer, align the pipe curvature with the LineTamer and install manually.

Before engaging any rollers, ensure that pipe is through machine with at least one foot of material past rerounding rollers.



PH01479-11-3-98

TX01589-1-11-99

## Readjusting Rollers

With pipe loaded in machine, turn the straightening rollers adjustment shaft clockwise until the roller shaft is in the optimum range, as indicated on the decal.

Turn the rerounding rollers adjustment shaft clockwise until the roller shaft is in the optimum range, as indicated on the decal.

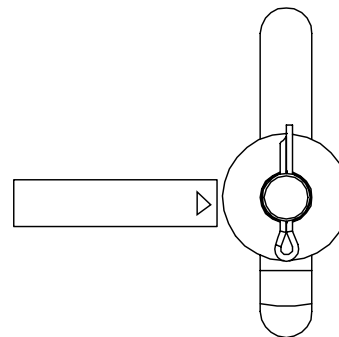

CD000502-2-1-99

TX01590-1-11-99

## Setting Rerounding Rollers

Ambient temperature conditions, density of pipe, and wall thickness will dictate what the actual setting needs to be. When the rollers are set too close, they will apply too much force and overcompensate for an out-of-round condition.

When the rollers are set too far apart they are not applying enough force to reround the pipe.

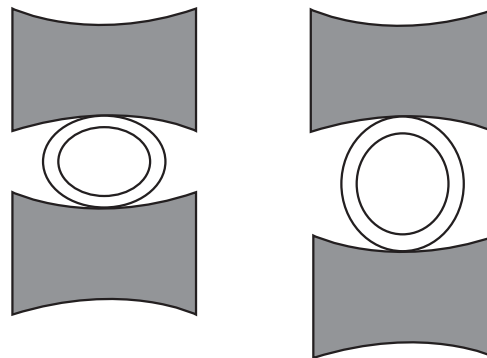

CD000496-10-29-98

TX01591-1-11-99



## Setting Straightening Rollers

If the straightening rollers are not set properly, the coil set will not be removed properly.

The proper setting will back bend the coiled pipe to remove coil set for safe handling. With the proper tension on the pipe the coil set will be forced out and the pipe will be straightened. The correct setting will also ensure that the pipe is centered in the rerounding rollers.

TX01592-1-11-99

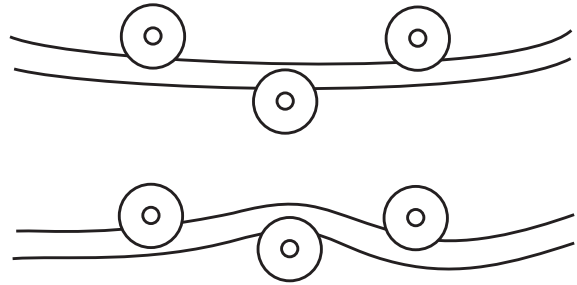

CD00499-10-29-98

## Precautions

Do not operate this equipment until you have carefully read, and understand the "Safety" and "Operation" sections of this manual, and all other equipment manuals that will be used with it.

Do not stand in front or behind preparation machine during pulling process.

Always operate machine from control-side of unit.

Operator should always be in radio contact with driver of pulling vehicle.

Never stand on preparation machine during operation.

Keep hands and legs away from machine during operation.

Do not sit or step on pipe during pull.

All non-participating personnel should be at least 15 feet away from

pipe coil and machine during pull.

TX00586-8-10-95



SAFE1ST12-22-92

## Pulling Pipe

Pull pipe through machine at speeds of 50 to 150 ft/min (less than 2 miles per hour).

The roller settings shown on the machine are guidelines only.

Lower speeds will require less applied force on the pipe.

Thinner wall pipe will also require less applied force on the pipe.

Do not exceed 150 ft/min. pulling speed.

Operation below 32o F is not recommended.

TX00596-2-1-99



PH01480-11-3-98



# Maintenance



## Preventative Maintenance

To insure optimum performance, the machine must be kept clean and well maintained.

With reasonable care, this machine will give years of service. Therefore, it is important that a regular schedule of preventive maintenance be kept.

Store machine inside, out of the weather, whenever possible.

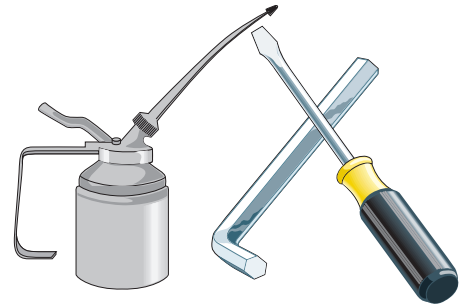

CD00142-11-2-94

TX00428-8-10-95

## Washing the Machine

An important factor in the service life of this machine is cleanliness. The machine should be cleaned with soap and water as needed.

When exposed to dust and mud in a field location, the machine should be washed at the end of each days work.



CD00178-9-15-95

TX00601-8-10-95

## Roller Adjustment Shafts

Periodically clean the threads on the roller adjustment shafts and apply a light coat of oil.

Oil all bearings and sleeves as required.

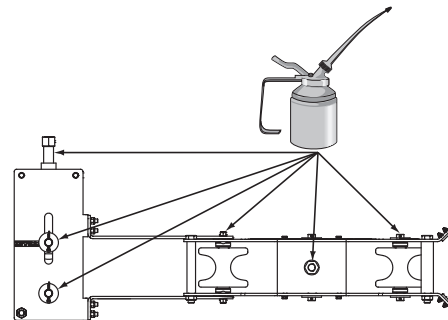

CD00522-1-1-99

TX01593-1-11-99



# Specifications



**Pipe Size:** 2" IPS (2.375" O.D.)

**Dimensions:** 44.44" (1129mm) long

19.75" (502mm) wide

20.38" (518mm) tall

**Weight:** 119 lbs. (54 kg)

TX01596-1-11-99

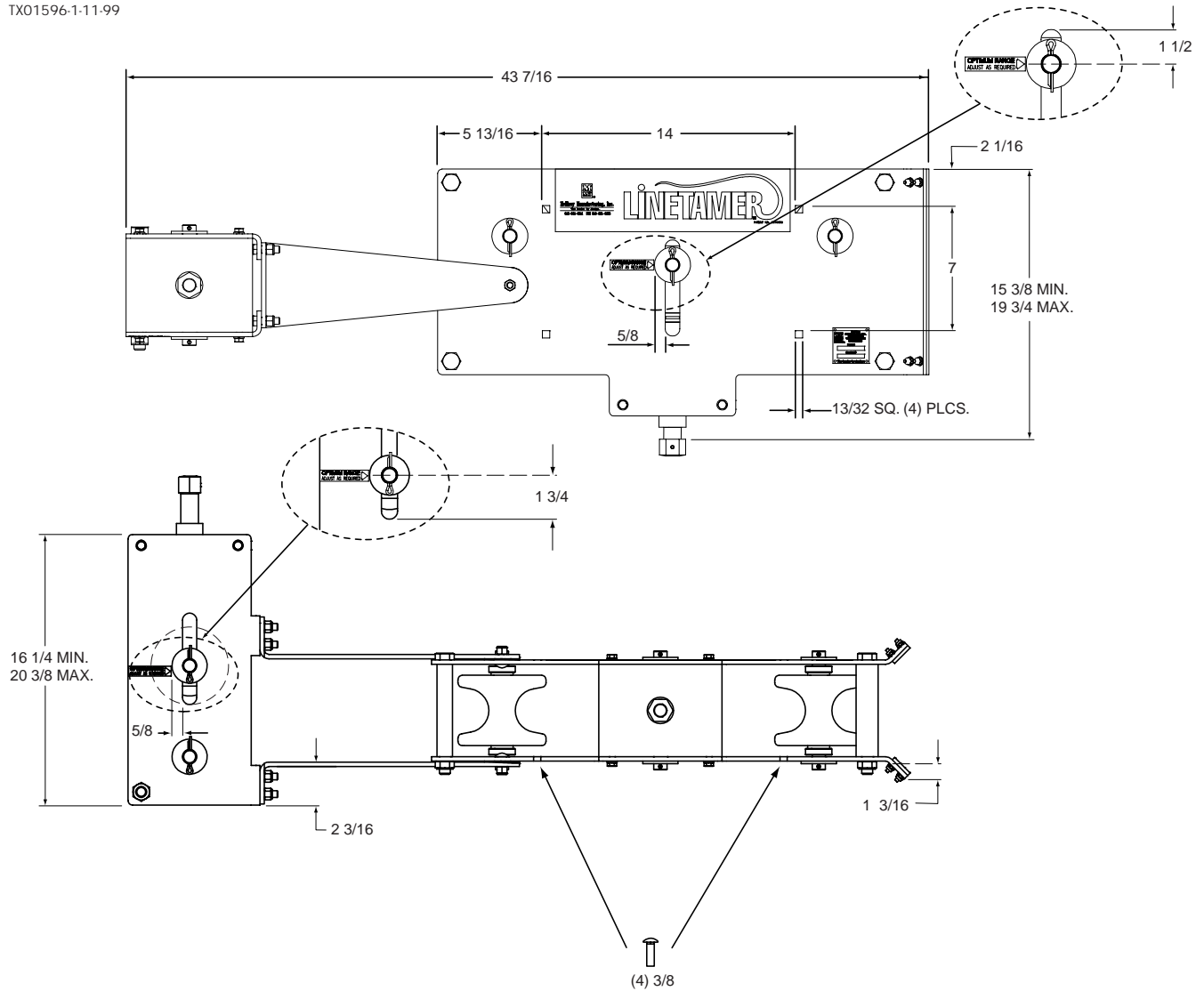

CD00528-2-1-99

## About this manual . . .

McElroy Manufacturing continually strives to give customers the best quality products available. This manual is printed on Teslin®, a polyolefin plastic film made for durable applications and harsh environments.

This manual is waterproof, tear resistant, grease resistant, abrasion resistant and the bonding quality of the printing ensures a readable, durable product.

Teslin does not contain any cellulose based materials and does not contribute to the harvesting of our forests. Teslin is non-toxic and does not contain any ozone-depleting constituents. Teslin can be safely disposed of in a landfill and will not leach into ground water.

TX001597-2-15-99



**McElroy Manufacturing, Inc.**

---

The leader by design

---

P.O.Box 580550 • Tulsa, Oklahoma 74158-0550  
(918) 836-8611 • Fax: (918) 831-9285